

# "CF6" SERIES BRONZE PUMP WITH 6" INTEGRAL TRAP SELF-PRIMING

O W N E R ' S M A N U A L

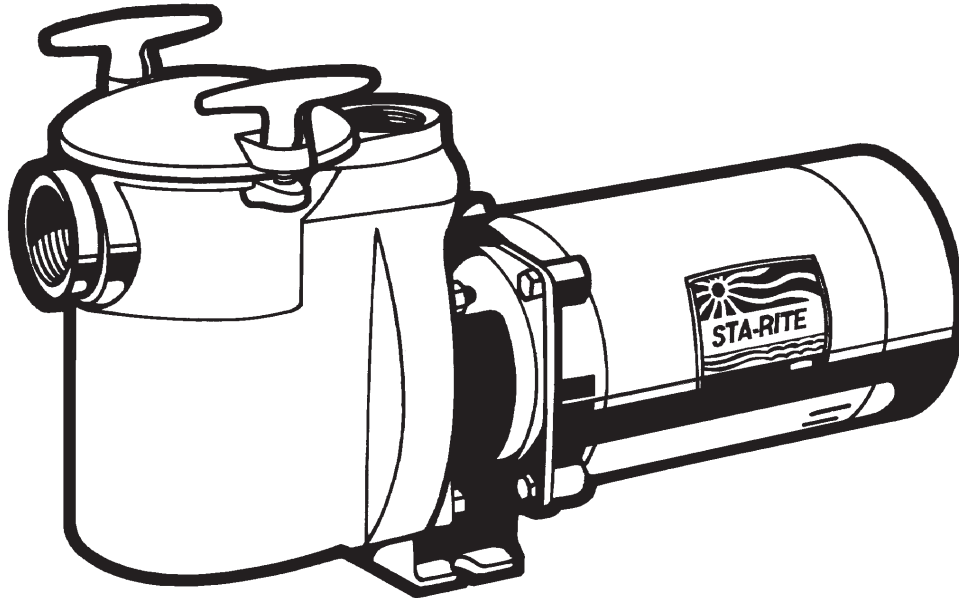

---

INSTALLATION, OPERATION & PARTS

## MODELS

<b>1-1/2 HP</b>	<b>2 HP</b>	<b>3 HP</b>	<b>3 HP</b>
CF6EF-81L	CF6EG-82L	CF6H-123	CF6H3-123
1Ø	1Ø	1Ø	CF6H3-123SA
			3Ø

This manual must be given to the owner/user of this pump

**Pentair Water Pool and Spa, Inc.**

© 2009 Pentair Water Pool and Spa, Inc. All rights reserved.  
1620 Hawkins Ave., Sanford, NC 27330 • (919) 566-8000  
10951 West Los Angeles Ave., Moorpark, CA 93021 • (805) 553-5000

Sta-Rite® and Pentair Water Pool and Spa® are registered trademarks of Pentair Water Pool and Spa, Inc. and/or its affiliated companies in the United States and/or other countries. Unless noted, names and brands of others that may be used in this document are not used to indicate an affiliation or endorsement between the proprietors of these names and brands and Pentair Water Pool and Spa, Inc. Those names and brands may be the trademarks or registered trademarks of those parties or others.

Printed in U.S.A.

# 'CF6' SERIES PUMP WITH TRAP

To avoid unneeded service calls, prevent possible injuries, and get the most out of your pump, READ THIS MANUAL CAREFULLY!

The Sta-Rite 'CF6' Series Self-Priming Centrifugal Pump:

- Is designed for use with swimming pools or as a centrifugal pump.
- Is an excellent performer; durable, reliable.

## Table of Contents

Safety Instructions .....2  
 Installation.....3-4  
 Electrical .....4-5  
 Operation .....6  
 Storage/Winterizing .....6-7  
 Pump Service .....7-8  
 Troubleshooting Guide .....9  
 Repair Parts List .....10  
 Warranty .....12

## Technical Support

Sanford, North Carolina  
(8 A.M. to 5 P.M. EST)

Moorpark, California  
(8 A.M. to 5 P.M. PST)

Phone: (800) 831-7133

Fax: (800) 284-4151

www.pentairpool.com www.staritepool.com

### IMPORTANT SAFETY INSTRUCTIONS

Always follow basic safety precautions with this equipment, including the following.

**WARNING** To reduce the risk of injury, do not permit children to use this product unless they are closely supervised at all times.

**CAUTION** This pump is for use with permanently installed pools and may also be used with hot tubs and spas if so marked. Do not use with storable pools. A permanently installed pool is constructed in or on the ground or in a building such that it cannot be readily disassembled for storage. A storable pool is constructed so that it may be readily disassembled for storage and reassembled to its original integrity.

### SAVE THESE INSTRUCTIONS

## READ AND FOLLOW SAFETY INSTRUCTIONS!

**!** This is the safety alert symbol. When you see this symbol on your system or in this manual, look for one of the following signal words and be alert to the potential for personal injury.

**DANGER** warns about hazards that **will** cause death, serious personal injury, or major property damage if ignored.

**WARNING** warns about hazards that **can** cause death, serious personal injury, or major property damage if ignored.

**CAUTION** warns about hazards that **will** or **can** cause minor personal injury or property damage if ignored.

**NOTICE** indicates special instructions not related to hazards.

Carefully read and follow all safety instructions in this manual and on equipment. Keep safety labels in good condition; replace if missing or damaged.

**WARNING** **Hazardous pressure** Incorrectly installed or tested equipment may fail, causing severe injury or property damage.

Read and follow instructions in owner's manual when installing and operating equipment. Have a trained pool professional perform all pressure tests.

1. Do not connect system to a high pressure or city water system.
2. Use equipment only in a pool or spa installation.
3. Trapped air in system can cause explosion. BE SURE all air is out of system before operating or testing equipment.

**Before pressure testing, make the following safety checks:**

Check all clamps, bolts, lids, and system accessories before testing.

Release all air in system before testing.

Tighten Sta-Rite trap lids to 30 ft. lbs. (4.1 kg-m) torque for testing.

Water pressure for test must be less than 25 PSI (7.5 kg/cm<sup>2</sup>).

Water Temperature for test must be less than 100° F. (38° C).

Limit test to 24 hours. After test, visually check system to be sure it is ready for operation. Remove trap lid and retighten hand tight only.

**NOTICE:** These parameters apply to Sta-Rite equipment only. For non-Sta-Rite equipment, consult manufacturer.

## INSTALLATION

**Only qualified, licensed personnel should install pump and wiring.**

### Pump mount must:

Be located away from corrosive or flammable liquids.

Have enough ventilation to maintain air temperature at less than the maximum ambient temperature rating (Max. Amb.) listed on the motor model plate. If this pump is installed in an enclosure/pump house, the enclosure must have adequate ventilation and air circulation to keep the temperature in the enclosure at or below the motor's rated ambient temperature whenever the pump is running.

Be solid - level - rigid - vibration free. (To reduce vibration and pipe stress, bolt pump to mount).

Allow pump suction inlet height to be as close to water level as possible.

Allow use of short, direction suction pipe (to reduce friction losses).

Allow for gate valves in suction and discharge piping.

Have adequate floor drainage to prevent flooding.

Be protected from excess moisture.

Allow adequate access for servicing pump and piping.

**NOTICE: Support all piping connected with pump!**

**▲ WARNING** **Fire and burn hazard.** Modern motors run at high temperatures. To reduce the risk of fire, do not allow leaves, debris, or foreign matter to collect around the pump motor. To avoid burns when handling the motor, let it cool for 20 minutes before trying to work on it.

### Piping:

Use at least 1-1/2" IPS PVC pipe with 5" trap. Use at least 2" pipe with 6" trap. Increase size if a long run is needed.

To avoid strains on the pump, support both suction and discharge pipes independently. Place these supports near the pump.

To avoid a strain left by a gap at the last connection, start all piping at the pump and run pipe **away** from the pump.

Never use a suction pipe smaller than pump suction connection.

To avoid airlocking, slope suction pipe slightly upward toward the pump.

**NOTICE:** To prevent flooding when removing pump for service, all flooded suction systems **must** have gate valves in suction and discharge pipes.

### Fittings:

Fittings restrict flow; for best efficiency use fewest possible fittings.

Avoid fittings which could cause an air trap.

Pool fittings must conform to International Association of Plumbing and Mechanical Officials (IAPMO) standards.

Use only non-entrapping suction fitting or double suction.

## POOL PUMP SUCTION REQUIREMENTS

**▲ WARNING** **Pump suction is hazardous and can trap and drown or disembowel bathers. Do not use or operate swimming pools, spas, or hot tubs if a suction outlet cover is missing, broken, or loose.** Follow the guidelines below for a pump installation which minimizes risk to users of pools, spas, and hot tubs.

### Entrapment Protection

The pump suction system *must* provide protection against the hazard of suction entrapment or hair entrapment/entanglement.

### Suction Outlet Covers

All suction outlet covers must be maintained. They must be replaced if cracked, broken, or missing.

See below for outlet cover certification requirements.

All suction outlets must have correctly installed, screw-fastened covers in place.

### Testing and Certification

Suction outlet covers must have been tested by a nationally recognized testing laboratory and found to comply with the latest ASME/ANSI Specification for *Suction Fittings For Use in Swimming Pools, Spas, Hot Tubs, and Whirlpool Bathtub Applications*.

## Outlets Per Pump

Provide at least two hydraulically balanced main drains, with covers (see below), for each swimming pool pump suction line. The centers of the main drains (suction fittings) must be at least three feet apart.

The system must be built so that it cannot operate with the pump drawing water from only *one* main drain (that is, there must be at least two main drains connected to the pump whenever it is running). (See Figure 1). However, if two main drains run into a single suction line, the single suction line may be equipped with a valve which will shutoff *both* main drains from the pump (see Figure 1).

More than one pump can be connected to a single suction line as long as the requirements above are met.

## Water Velocity

The maximum water velocity through any suction outlet must be 1.5 feet per second unless the outlet complies with the latest ASME/SNSI Specification for *Suction Fittings For Use in Swimming Pools, Spas, Hot Tubs, and Whirlpool Bathtub Applications*. In any case, do not exceed the suction fittings maximum designed flow rate.

If 100% of the pump's flow comes from the main drain system, the maximum water velocity in the pump suction hydraulic system must be six feet per second or less even if one main drain (suction fitting) is completely blocked. The flow through the remaining main drain(s) must comply with the latest ASME/ANSI Specification for *Suction Fittings For Use in Swimming Pools, Spas, Hot Tubs, and Whirlpool Bathtub Applications*.

## ELECTRICAL

**⚠ WARNING** Hazardous voltage. Can shock, burn or cause death. Ground pump before connecting to power supply.

**⚠** Ground motor before connecting to electrical power supply! Failure to ground pump motor can cause serious or fatal electrical shock hazard!

**⚠** Do not ground to a gas supply line!

**⚠** To avoid dangerous or fatal electrical shock, turn OFF power to motor before working on electrical connections.

**⚠** Ground Fault Circuit Interrupter (GFCI) tripping indicates an electrical problem. If GFCI trips and will not reset, have a qualified electrician inspect and repair electrical system.

**⚠** Exactly match supply voltage to nameplate voltage! Incorrect voltage can cause fire or seriously damage motor and voids warranty! If in doubt consult a licensed electrician.

### Voltage:

Voltage at motor must be not more than 10% above or below motor nameplate rated voltage or motor may over-heat, causing overload tripping and reduced component life. If voltage is less than 90% or more than 110% of rated voltage when motor is running at full load, consult power company.

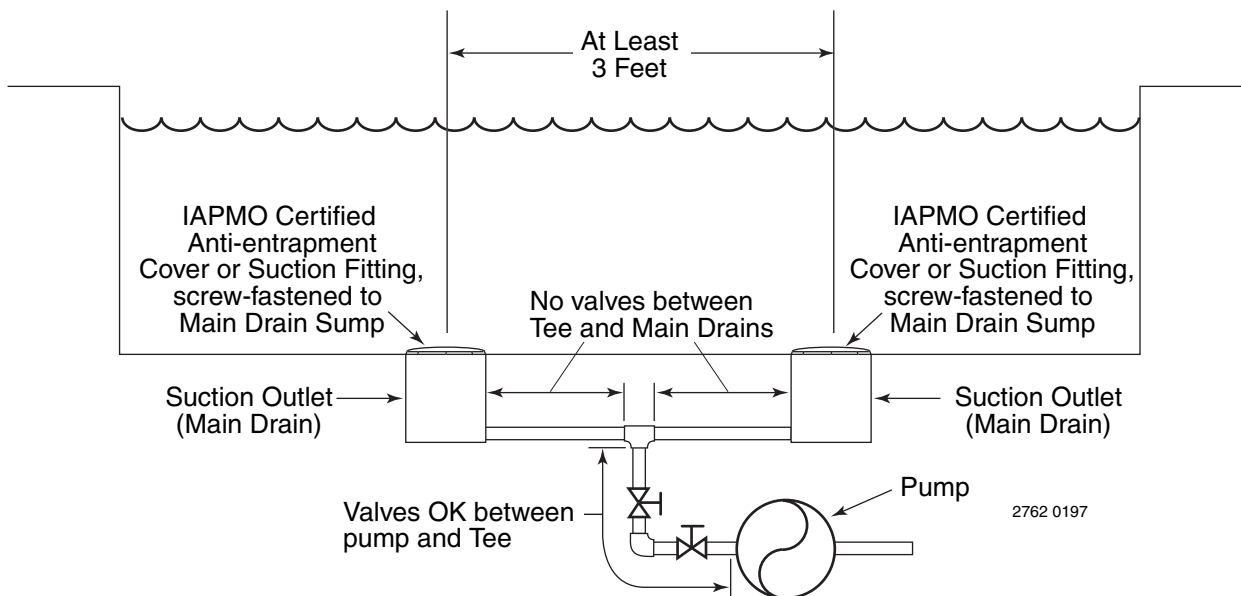

Figure 1 – Recommended pump suction layout.

## Grounding/Bonding:

Install, ground, bond and wire motor according to local or National Electrical Code requirements.

Permanently ground motor. Use green ground terminal provided under motor canopy or access plate (See Figure 2); use size and type wire required by code. Connect motor ground terminal to electrical service ground.

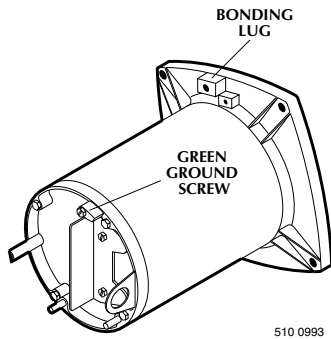
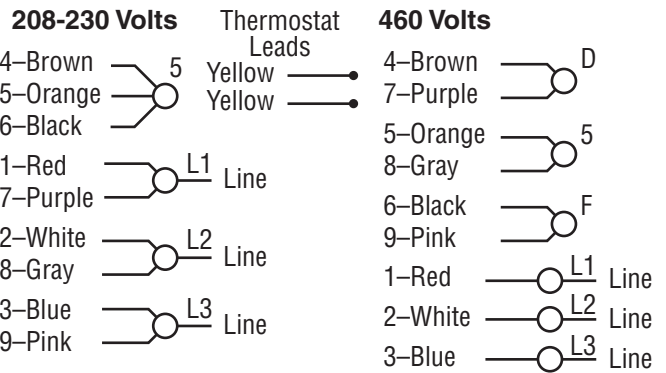

Figure 2: Typical ground screw and bonding lug locations

Bond motor to pool structure. Use a solid copper conductor, size No. 8 AWG (8.4 sq. mm) or larger. Run wire from external bonding lug (see Figure 2) to reinforcing rod or mesh.

Connect a No. 8 AWG (8.4 sq. mm) solid copper bonding wire to the pressure wire connector provided on the motor housing and to all metal parts of the swimming pool, spa, or hot tub and to all electrical equipment, metal piping or conduit within 5 feet (1.5 m) of the inside walls of swimming pool, spa, or hot tub.



To reverse the motor, interchange any two line leads (L1, L2, L3)

Figure 3: 3-Phase connection diagram. If the diagram on the motor nameplate does not match this one, follow the motor nameplate.

## Wiring:

Pump must be permanently connected to circuit. Table I gives correct wire and circuit breaker sizes for the pump alone. If other lights or appliances are also on the same circuit, be sure to add their amp loads to pump amp load before figuring wire and circuit breaker sizes. (If unsure how to do this or if this is confusing, consult a licensed electrician.) Use the load circuit breaker as the master on-off switch.

Install a Ground Fault Circuit Interrupter (GFCI) in circuit; it will sense a short-circuit to ground and disconnect power before it becomes dangerous to pool users. For size of GFCI required and test procedures for GFCI, see manufacturer's instruction.

In case of power outage, check GFCI for tripping (which will prevent normal pump operation). Reset if necessary.

**NOTICE:** If you do not use conduit when wiring motor, be sure to seal wire opening on end of motor to prevent dirt, bugs, etc., from entering.

**NOTICE:** Three-phase models require magnetic motor starters and external overload protection. If in doubt about the procedure, consult a licensed electrician. See Figure 3 for wiring connection diagrams. See Table 1 for correct wire and circuit breaker sizes.

TABLE I - RECOMMENDED CIRCUIT BREAKER SIZE AND WIRING DATA

Model No.	Motor H.P.	Voltage/Hz/Phase	Max. Load Amps	Branch Circuit Breaker Rating (amps)	Wire Temp. Rating-°C	Wire Gauge Size			
						Dist. in Ft. (M)-Service Motor			
						0-100' (0-30)	101-200' (31-60)	201-300' (61-90)	} AWG (mm²) Wire Gauge Size
CF6EF-81L	1-1/2	230V/60/1	10.4	15	75	14(2)	14(2)	12(3)	
CF6EG-82L	2	230V/60/1	11.2	15	75	14(2)	14(2)	12(3)	
CF6H-123	3	230V/60/1	17.2	30	75	10(5.5)	10(5.5)	10(5.5)	
CF6H3-123 CF6H3-123SA	3	208-230/460V/60/3	9.8-9.6/4.8	15/15	75	14/14(2/2)	14/14(2/2)	14/14(2/2)	

## OPERATION

**⚠ NEVER run pump dry. Running pump dry may damage seals, causing leakage and flooding. Fill pump with water before starting motor.**

**⚠ Before removing trap cover:**

1. STOP PUMP before proceeding.
2. CLOSE GATE VALVES in suction and discharge pipes.
3. RELEASE ALL PRESSURE from pump and piping system.

**⚠ If pump is being pressure tested, be sure pressure has been released before removing trap cover.**

**⚠ WARNING Fire and burn hazard.** Modern motors run at high temperatures. To reduce the risk of fire, do not allow leaves, debris, or foreign matter to collect around the pump motor. To avoid burns when handling the motor, let it cool for 20 minutes before trying to work on it. An automatic internal cutoff switch protects the motor from heat damage during operation.

**⚠ Do not block pump suction! To do so with body may cause severe or fatal injury. Small children using pool must ALWAYS have close adult supervision.**

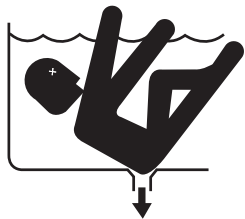
<b>⚠ DANGER</b>	<b>Hazardous suction. Can trap hair or body parts, causing severe injury or death.</b>
	Do not block suction.

### Priming Pump:

Release all pressure from filter, pump and piping system; see the filter owner's manual.

In a flooded suction system (water source higher than pump), pump will prime itself when suction and discharge valves are opened.

If pump is not in a flooded suction system, unscrew T-bolt trap handles and remove trap cover; fill trap and pump with water.

Clean and lubricate trap cover O-Ring with petroleum jelly each time it is removed.

Replace trap cover on trap; tighten T-bolt trap handles. Pump should prime now. Priming time will depend on vertical length of suction lift and horizontal length of suction piping.

If pump does not prime, make sure that all valves are open, suction pipe end is under water and that there are no leaks in suction pipe. See Troubleshooting Guide, Page 9.

## STORAGE/WINTERIZING

**⚠** Allowing pump to freeze will damage pump and void warranty!

**⚠** Do not use anti-freeze solutions (except propylene glycol) in your pool/spa system. Propylene glycol is non-toxic and will not damage plastic system components; other antifreezes are highly toxic and may damage plastic components in the system.

Drain all water from pump and piping when expecting freezing temperatures or when storing pump for a long time (see instructions below).

Keep motor dry and covered during storage.

To avoid condensation/corrosion problems, **do not** cover pump with plastic film or bags.

For outdoor/unprotected installations:

1. Enclose entire system in a weatherproof enclosure.
2. To avoid condensation/corrosion damage, allow ventilation; do not wrap system in plastic film.
3. Use a 40% propylene glycol/60% water solution to protect pump to -50 degrees F.

### Draining Pump

1. Pump down water level below all inlets to the pool.

**⚠ WARNING Hazardous voltage. To avoid dangerous or fatal electrical shock hazard, turn OFF power to motor before draining pump or working on pump or motor.**

2. Remove trap cover and use low pressure air to blow accumulated water from the piping system.
3. Cap inlet piping after draining to keep water out of the pipes.
4. To prevent pump from freezing, remove trap cover and drain the tank body through the drain plug (Key 10, Page 10). Clean pump thoroughly; replace trap cover.
6. Be sure motor is kept dry and covered.

## Startup For Winterized Equipment

1. Remove any temporary weather protection placed around system for shutdown.
2. Follow filter manufacturer's instructions for reactivation of the filter.
3. Inspect all electrical wiring for damage or deterioration over the shutdown period. Have a qualified serviceman repair wiring as needed.
4. Inspect and tighten all watertight connections.
5. Open all valves in suction and return piping.
6. Remove any winterizing plugs in piping system.
7. Drain all anti-freeze from system.
8. Close all drain valves and replace all drain plugs in system.
9. Prime pump according to instructions on Page 6.

## PUMP SERVICE

**▲ WARNING** Hazardous voltage. Can shock, burn or cause death. Disconnect power before working on pump or motor.

Pump should only be serviced by qualified personnel.  
Be sure to prime pump (Page 6) before starting.



### Before removing trap cover:

1. STOP PUMP before proceeding.
2. CLOSE GATE VALVES in suction and discharge pipes.
3. RELEASE ALL PRESSURE from pump and piping system.

**▲ WARNING** To avoid dangerous or fatal electrical shock hazard, turn OFF power to motor before working on pump or motor!

Aside from lubricating trap cover O-Ring, no lubrication or mechanical maintenance is needed beyond reasonable care and periodic cleaning.

If shaft seal is worn or damaged, repair as follows:

### Pump Disassembly:



### Disconnect power to pump motor.

Be sure gate valves on suction and return piping are closed before starting work.

Release all pressure by opening all vents before starting work.

1. Drain pump by removing drain plugs on bottom of pump body and trap body.
2. Be sure there is no pressure in trap body; remove trap cover.

3. Remove nuts (Key No. 11A, Page 10), which hold volute in place, thus releasing the volute from the adapter.
4. Hold the motor shaft extension stationary with pliers, and turn the impeller counter-clockwise until it is free from the shaft.  
**NOTICE:** 3-Phase motors use an impeller screw. Remove the impeller screw (left-hand thread—turn **clockwise**) before removing impeller. Inspect the washer for damage, cracks, etc. Replace if necessary.
5. Remove the adapter (Key No. 4) from the motor by removing the capscrews (Key No. 5).

## REMOVAL OF OLD SEAL / INSTALLATION OF NEW SEAL

1. Drive the old seal out of the adapter. Use a piece of pipe or tubing as shown in Figure 4.

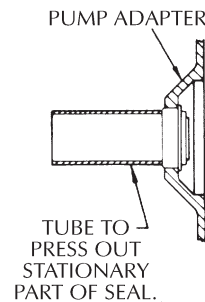

Figure 4

2. Clean the cavity in the adapter. Before installing, coat seal case with sealant compound. Press seal into adapter with a tube or pipe of the correct size to press on the seal rim only, as shown in Figure 5.

**NOTICE:** Do not touch or scratch the polished carbon face of the seal with the pressing tool.

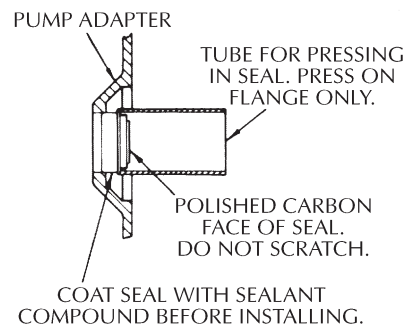
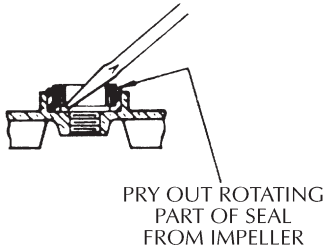

Figure 5

3. Pry loose the ceramic seal in impeller, apply screwdriver between seat and cavity in impeller (Figure 6). Clean cavity from which seat was removed.



**Figure 6**

4. Lubricate the rubber ring in the impeller with a soap solution. Press seat into impeller cavity (Figure 7). If a tool or pipe is necessary to press ceramic seat correctly, use a cardboard disc or washer to protect the highly polished ceramic surface of the new seal.

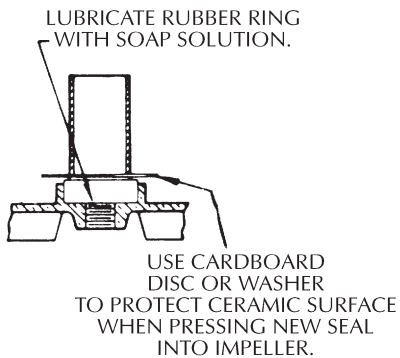

**Figure 7**

### **Pump Reassembly:**

1. Loosen shaft extension (Key No. 2), so it may be moved along the shaft with ease. Replace adapter on motor and tighten capscrews (Key No. 5).
2. Make certain seal faces are clean. Hold the motor shaft extension stationary and tighten impeller on to shaft.

**NOTICE:** 3-Phase models use an impeller screw. For these models, install the impeller washer and lock screw (left-hand thread—turn counterclockwise) before proceeding to Step 3.

3. Leaving volute gasket off, place volute on adapter and tighten nuts (Key No. 11A).
4. Push shaft extension and impeller toward volute until impeller touches volute. Tighten set screws (Key No. 3) in place. Remove volute and install gasket (Key No. 8). Place volute on adapter and tighten nuts (Key No. 11A). By this procedure, the proper clearance between impeller face and volute has been established.

# TROUBLESHOOTING GUIDE

**⚠ WARNING** **Hazardous voltage. Can shock, burn or cause death.** Disconnect power before working on pump or motor.

**⚠** **Read and understand safety and operating instructions in this manual before doing any work on pump!**

**⚠** **Only qualified personnel should electrically test pump motor!**

## FAILURE TO PUMP; REDUCED CAPACITY OR DISCHARGE PRESSURE

### A. SUCTION LEAKS/LOST PRIME:

1. Pump must be primed; make sure that pump volute and trap are full of water. See priming instructions, Page 6.
2. Make sure there are no leaks in suction piping.
3. Make sure suction pipe inlet to pump is well below the water level to prevent pump from sucking air.
4. If suction trap O-Ring is defective, replace it.
5. Suction lift of 8 feet (2.4M) will reduce performance. Suction lift of more than 10 feet (3M) will prevent pumping and cause pump to lose prime. In either case, move pump closer (vertically) to water source. Make sure suction pipe is large enough.

### B. CLOGGED PIPE/TRAP/IMPELLER, WORN IMPELLER:

1. Make sure suction trap is not clogged; if it is, clean trap and strainer.
2. Make sure impeller is not clogged (follow instructions under "Removing Old Seal," Page 7; check impeller for clogging; follow instructions under "Installing New Seal," Page 7 for reassembly).

3. Impeller may be worn. If so, order replacement parts from Repair Parts List, Page 10.
4. Pump may be trying to push too high a column of water. If so, a "higher head" pump is needed.

### C. ELECTRICAL

1. Pump may be running too slowly; check voltage at motor terminals and at meter while pump is running. If low, see wiring instructions or consult power company. Check for loose connections.
2. Pump may be too hot.
  - A. Check line voltage; if less than 90% or more than 110% of rated voltage consult a licensed electrician.
  - B. Increase ventilation.
  - C. Reduce ambient temperature.
  - D. Tighten any loose connections.

### D. MECHANICAL TROUBLES AND NOISE

1. If suction and discharge are not adequately supported, pump assembly will be strained. See "Installation," Page 3.
2. Do not mount pump on a wooden platform! Securely mount on a concrete platform for quietest performance.

**EXPLODED VIEW**  
**"CF6" BRONZE SERIES**  
**Self Priming Centrifugal Pump**

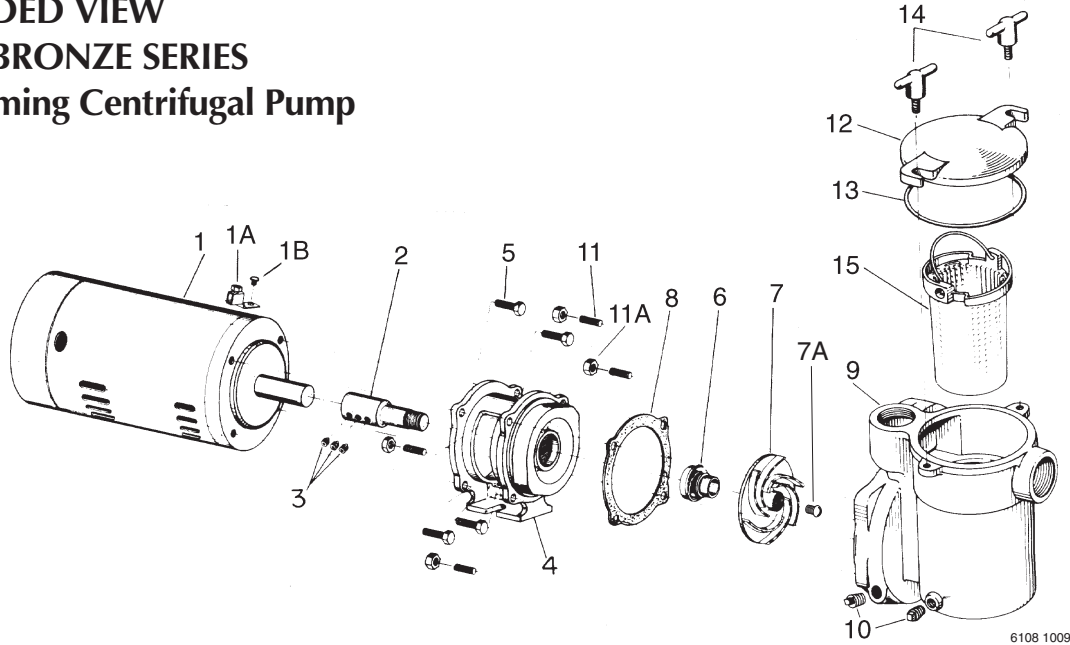

**REPAIR PARTS LIST**

Key No.	Part Description	Qty.	CF6EF-81L	CF6EG-82L	CF6H-123	CF6H3-123
			1-1/2 HP 230V	2 HP 230V	3 HP 230V	3 HP 230/460V
1	Motor	1	AE600FHL	AE600GHL	C218-195	C218-1612
1A	Lug - Bonding	1	U17-568	U17-568	U17-568	U17-568
1B	Screw - #10 - 32 x 1/2"	1	U30-692SS	U30-692SS	U30-692SS	U30-692SS
2	Stub Shaft Assembly	1	C110-17	C110-17	C110-17	C110-17A
3	Set Screw 1/4 - 20 x 5/16"	3	U30-754SS	U30-754SS	U30-754SS	U30-754SS
4	Adapter	1	C2-57D	C2-57D	C2-57D	C2-57D
5	Capscrew - 3/8 - 16 x 5/8"	4	U30-72SS	U30-72SS	U30-72SS	U30-72SS
6	Shaft Seal	1	U109-136SS	U109-136SS	U109-136SS	U109-136SS
7	Impeller	1	C5-181D	C5-182D	C5-203D	C5-203D
7A	Impeller Screw	1	-	-	-	C30-20
	• Impeller Washer	1	-	-	-	U43-51D
8	Gasket	1	C20-72	C20-72	C20-72	C20-72
9	Volute & Trap Body	1	C1-201DB	C1-201DB	C1-201DB	C1-201DB
10	Pipe Plug, 1/4" NPT	2	U78-57DT	U78-57DT	U78-57DT	U78-57DT
11	Stud - 3/8 - 16 x 1-7/16"	4	U30-36SS	U30-36SS	-	-
11A	Stud - 3/8 x 1-1/4"	4	-	-	U30-22SS	U30-22SS
	• Nut 3/8-16	4	U36-38SS	U36-38SS	U36-38SS	U36-38SS
12	Trap Cover	1	C3-78D	C3-78D	C3-78D	C3-78D
13	Cord Ring	1	U9-46	U9-46	U9-46	U9-46
14	Trap Handle	2	C154-25	C154-25	C154-18D	C154-18D
15	Strainer Basket	1	C108-11P	C108-11P	C108-11P	C108-11P
	• "Use Copper Conductors"	1	U27-317	U27-317	U27-317	U27-317
	• "For Use w/ Pools & Spas"	1	U27-425	U27-425	U27-425	U27-425
	• Model Plate	1	U33-6	U33-6	U33-6	U33-6
	• "Caution...permanent pools"	1	U27-599	U27-599	U27-599	U27-599
	• "Caution...Rotary seal..."	1	U63-13	U63-13	U63-13	U63-13
	• Decal '230 Volts'	1	U27-153	U27-153	U27-153	U27-153
	• "Suitable for outdoor use..."	1	U27-255	U27-255	U27-255	U27-255
<b>SERVICE KITS</b>						
	Seal and Gasket Kit	1	PP1150	PP1150	PP1150	PP1150
	Trap Basket & O-Ring Kit	1	PP2061	PP2061	PP2061	PP2061
	Lock Handle Kit	1	PP2050	PP2050	PP2050	PP2050

• Not illustrated



# PENTAIR WATER POOL AND SPA<sup>®</sup> LIMITED WARRANTY

This product is manufactured by Pentair Water Pool and Spa, Inc. and is warranted to be free of defects in material and/or workmanship for one (1) year from the original date of installation.

The foregoing warranties relate to the original consumer purchaser ("Purchaser") only. Pentair Water Pool and Spa, Inc. shall have the option to repair or replace the defective product, at its sole discretion. Purchasers must pay all labor and shipping charges necessary to replace the product covered by this warranty. Requests for warranty service must be made through the installing dealer. This warranty shall not apply to any product that has been subject to negligence, misapplication, improper installation or maintenance, or other circumstances which are not in Pentair Water Pool and Spa's direct control. Failure to have product installed by a professional in compliance with local codes will void any and all manufacturers warranty.

This warranty sets forth Pentair Water Pool and Spa's obligation and Purchaser's exclusive remedy for defective products.

PENTAIR WATER POOL AND SPA SHALL NOT BE LIABLE FOR ANY CONSEQUENTIAL, INCIDENTAL OR CONTINGENT DAMAGES WHATSOEVER.

THE FOREGOING WARRANTIES ARE EXCLUSIVE AND IN LIEU OF ALL OTHER EXPRESS WARRANTIES. IMPLIED WARRANTIES, INCLUDING BUT NOT LIMITED TO THE IMPLIED WARRANTIES OF MERCHANTABILITY AND FITNESS FOR A PARTICULAR PURPOSE, SHALL NOT EXTEND BEYOND THE DURATION OF THE APPLICABLE EXPRESS WARRANTIES PROVIDED HEREIN.

Some states do not allow the exclusion or limitation of incidental or consequential damages or limitations on how long an implied warranty lasts, so the above limitations or exclusion may not apply to you. This warranty gives you specific legal rights and you may also have other rights which vary from state to state.

Supersedes all previous publications.

**For technical information about this product, contact the installer or call Customer Support at:**

**Phone: (800) 831-7133 Fax: (800) 284-4151**

**Visit [www.pentairwater.com](http://www.pentairwater.com) and [staritepool.com](http://staritepool.com)**

Complete bottom portion completely and mail to Sta-Rite, Attn.: Warranty Dept., 293 Wright St., Delavan , WI 53115

**STA-RITE<sup>®</sup>**



## Warranty Registration Card

Name \_\_\_\_\_

New installation  Replacement \_\_\_\_\_

Address \_\_\_\_\_

Years pool has been in service  less than 1  1-3  3-5  5-10 \_\_\_\_\_

City \_\_\_\_\_ State \_\_\_\_\_ Zip \_\_\_\_\_

**This product was purchased from:**

Installation (or Purchase) Date \_\_\_\_\_

Company name \_\_\_\_\_

Product Purchased \_\_\_\_\_

Address \_\_\_\_\_

Model Number \_\_\_\_\_

City \_\_\_\_\_ State \_\_\_\_\_ Zip \_\_\_\_\_