

# AmerScapes® Installation Instructions

## IMPORTANT SAFETY INSTRUCTIONS *READ AND FOLLOW ALL INSTRUCTIONS* SAVE THESE INSTRUCTIONS

### Table of Contents

SECTION I.	DESIGN AND LIGHTING TECHNIQUES .....	2
SECTION II.	TRANSFORMER INSTALLATION GUIDELINES .....	3
SECTION III.	CABLE INSTALLATION GUIDELINES .....	4
SECTION IV.	PRECAUTIONS AND WARNINGS .....	4
SECTION V.	INSTALLING THE SYSTEM .....	6
SECTION VI.	COMMON INSTALLATIONS/LAYOUTS .....	8
SECTION VII.	TROUBLESHOOTING .....	8
SECTION VIII.	TECHNICAL DATA .....	10

### WARNING

Before installing this product, read and follow all warning notices and instructions accompanying this filter. Failure to follow safety warnings and instructions can result in severe injury, death, or property damage. Call (800) 831-7133 for additional free copies of these instructions.

### Important Notice



Attention Installer.

This manual contains important information about the installation, operation and safe use of this product. This information should be given to the owner/operator of this equipment.

#### Pentair Pool Products

1620 Hawkins Rd., Sanford, NC 27330 • (919) 774-4151  
10951 West Los Angeles Ave., Moorpark, CA 93021 • (805) 523-2400



## SECTION I. DESIGN AND LIGHTING TECHNIQUES

- A. Before selecting your lighting fixtures, take a careful overview of your property. Determine which areas of the yard you want to see brightly lit and which areas simply need ambient light.
1. For best results, try the various lighting techniques outlined on opposite page. It is best not to over light. A little light goes a long way, especially in dark areas.
  2. Once you have determined the lighting plan, you are ready to select the appropriate fixtures. The first recommended step of the installation is to test the light before actually installing the system.
    - a. Simply hook up the low voltage transformer to the main cable (usually 100 ft. in kits) and experiment with the position, height and placement of each light at night. This will allow you to review all the lighting techniques that professional designers use.

Technique	Effect	Positioning
Uplight	Attention getting & dramatic	Stationary, vertical ground light
Downlight	Creates a mood & provides security	Light aimed downward from above
Directional	Emphasizes points of interest	Adjustable fixture aimed at object
Pathlight	Provides welcome effect	Above ground spread light
Accent	Adds dimensional effect(s)	Low level light often staggered
Silhouette	Adds drama, intrigue	Backlighting objects
Moonlight	Creates interesting shadows, adds drama	Lighting in trees at various angles
Security	Provides safety & deters crime	Flood lighting entrances/exits
Grazing	Emphasizes texture, adds dimension	Fixture close to object and uplighted
Crossing	Adds depth and dimension	Criss-crossing lights
Mirror	Adds beauty and romantic effects	Backlighting objects to reflect on water

### **DANGER**

#### **Risk of Electrical Shock or Electrocution.**

This lighting system must be installed by a licensed or certified electrician or a qualified pool serviceman in accordance with the National Electrical Code and all applicable local codes and ordinances. Improper installation will create an electrical hazard which could result in death or serious injury to pool users, installer, or others due to electrical shock, and may also cause damage to property. Read and follow the specific instructions below.

Always disconnect power to the pool light at the circuit breaker before servicing the light. Failure to do so could result in death or serious injury to serviceman, users, or others due to electrical shock.



## SECTION II. TRANSFORMER INSTALLATION GUIDELINES

- A. There are two main ingredients of a low voltage lighting system, the transformer and the wiring cable.
  - 1. Both of these items have necessary guidelines that must be followed. If you are using a professional kit these guidelines are predetermined. However, when designing or customizing a low voltage lighting system, you should fully understand the information outlined below.

---

**Equation: Watts = Volts X Amps**

**Example: 12 volts x 10 amps = 120 watts.**

---

- B. Transformer guidelines.
  - 1. Achieving low voltage is accomplished with an electrical device that “transforms” the household voltage (110V) to a 12V output. One side of the transformer will normally plug into the house receptacle (input). The other side of the transformer will have a 12V cable attached (typically 100 ft.). This cable carries the electrical current.
    - a. If used outdoors, the transformer must have a rain-tight casing. The markings — “Suitable for Wet Location” and “UL” must appear on the casing.
    - b. The transformer will have a maximum rating (VA) and must be observed. Simply count the number of bulb watts on the system. This number should be equal or less than the rating on the transformer, i.e. five (5) - 13 watt light bulbs = 65 watts. The transformer VA rating must be equal to or more than 65 watts (output).

 <b>WARNING</b>	
	<b>Failure to bring the electrical system of the residence up to code requirements before installing this lighting system will create an electrical hazard which could result in death or serious injury to users, installers, or others due to electrical shock, and may also cause damage to property.</b>



**Failure to bring the electrical system of the residence up to code requirements before installing this lighting system will create an electrical hazard which could result in death or serious injury to users, installers, or others due to electrical shock, and may also cause damage to property.**

- c. Transformers come in a wide variety of ratings. For best efficiency, we recommend that the total number of watts be within 80% of the transformer rating, but should not exceed it.
- 2. The transformer must be mounted at least 12 in. above the ground and secured to a solid object. Never allow the transformer to lie on the ground.
- 3. The transformer must be plugged into a Ground Fault Interrupt (GFI) receptacle with an approved watertight cover. Consult with local electric codes for specific information and guidelines.
- 4. Transformers are often equipped with an automatic switching device (timer, photocell, etc.). The switching can be tailored to your individual requirements. Consult with a certified electrician.

### SECTION III. CABLE INSTALLATION GUIDELINES

- A. Landscape lighting cable comes in a variety of sizes (thickness). Thicker cable is required for carrying higher power.
- B. The cable jacket is made of PVC material and can be buried in the ground or left on the top soil. It is weather-resistant, insulated stranded copper wire. The common sizes available are 16, 14 and 12 gauge. The lower the gauge, the thicker the cable.
  - 1. Each size cable is rated at a maximum capacity, see “Amperage” in the glossary. To determine the cable size, please refer to the charts below.

<b>Cable Size at 100 ft.</b>	<b>Max. Total Bulb Watts per Cable Run</b>
16/2 (thin cable) at 100 ft.	no more than 45 watts
14/2 (medium cable) at 100 ft.	no more than 72 watts
12/2 (thick cable) at 100 ft.	no more than 125 watts

#### **Voltage Drop Formula**



Total no. of Bulb Watts X Length of Cable Run ÷ Factoring no. of Cable = Voltage Drop

<u>Cable Size</u>	<u>Factoring No.</u>	<u>example</u>	<u>125 watts x 100 ft.</u>	<u>= 1.66</u>
16/2	= 2200	(12/2 cable)	7500	
14/2	= 3500			
12/2	= 7500			

- 2. The voltage drop should not exceed more than 2.0V. A drop of more than 2.0V will adversely affect the light output. To reduce the voltage drop, refer to the following procedures.
  - a. Reduce the number of fixtures.
  - b. Reduce the number of bulb watts.
  - c. Reduce the cable run in distance.
  - d. Increase the cable size.
  - e. Add additional cable run(s).

### SECTION IV. PRECAUTIONS AND WARNINGS

- A. Power supply transformers have a maximum rating. **DO NOT OVERLOAD.**

 <b>WARNING</b>	
	Failure to bring the electrical system of the residence up to code requirements before installing this lighting system will create an electrical hazard which could result in death or serious injury to users, installers, or others due to electrical shock, and may also cause damage to property.

1. Simply count the number of bulb watts on the system, i.e. five (5) - 13 watt bulbs = 65.
  2. Do not use a transformer less than a 65 rating (VA).
- B. Plug the transformer into a GFI receptacle with a UL-approved wet protected receptacle cover.
1. Check with local electrical codes before installation.
  2. The high voltage receptacle must be thoroughly protected from electrical shorts and wet conditions.
- C. The transformer must be mounted at least 12 in. above the ground and attached to a solid surface.
- D. Make sure that all electrical connections are secure and tight.
- E. Do not force ground spike into place. Wet the ground first with water for easy insertion.
- F. **DONOT OVERLOAD THE CABLE.**

** DANGER**



**Risk of Electrical Shock or Electrocution.**

Position the AmerGlow™ and transformer connection so that they are away from water or moisture proof the connections with silicone-type gel. Failure to keep electrical connections moisture-proofed can create an electrical hazard that can cause severe personal injury or property damage.

1. Each size cable is rated for a maximum bulb wattage. Refer to Section III, Cable Installation Guidelines in this booklet.
- G. Do not add cable, fixtures or change light bulbs without counting the load on the following: transformer, cable, and cable run (distance in feet).

** DANGER**



**Risk of Electrical Shock or Electrocution.**

This lighting system must be installed by a licensed or certified electrician or a qualified pool serviceman in accordance with the National Electrical Code and all applicable local codes and ordinances. Improper installation will create an electrical hazard which could result in death or serious injury to pool users, installer, or others due to electrical shock, and may also cause damage to property. Read and follow the specific instructions below.  
Always disconnect power to the pool light at the circuit breaker before servicing the light. Failure to do so could result in death or serious injury to serviceman, users, or others due to electrical shock.

1. Refer to Section III, Cable Installation Guidelines in this booklet.

## SECTION V. INSTALLING THE SYSTEM

- A. Mount the transformer to a rigid surface at least 12 in. above the ground.
  - 1. Most transformers come with mounting screws and/or anchor set.
  - 2. The transformer should be mounted vertically with the wire connections facing the ground.
- B. Plug the three-prong plug into a GFI receptacle only. This will protect the system in case of a short or an overload.
  - 1. Ensure that the receptacle cover is a UL approved watertight enclosure. This will keep water from direct contact with the plug.
  - 2. Consult your local electrical code and national code before installing any outdoor lighting system.
- C. Attaching the 12V Cable.
  - 1. Once the transformer is securely in place, take the main cable and split it into a “V” about 12 in. apart. Strip approx. 1/2 in. to 3/4 in. of insulation away exposing the copper strands.
  - 2. Do not cut the copper strands. Attach a spade connector to each end, crimp on. A crimping plier is required.
  - 3. Proceed to attach the spade connectors to the screw terminals on the bottom of the transformer.
    - a. Be aware of the cable markings; rigid, smooth and/or printed sides. This will determine the positive and neutral sides for “polarity”.
    - b. For best results, be consistent with polarity when wiring each light fixture to the main cable (like-to-like sides).
  - 4. The cable is then “run” to the desired points of light. Depending on the design, the wire can be run in various configurations.
    - a. See Section V, Common Installation/Layouts, for examples of layouts; straight out, “V” shaped pattern, “T” shaped pattern, “Y” shaped pattern, circular, square, or rectangular run.
    - b. The primary consideration is to reduce the amount of cable on a run by using the shortest possible distance.
    - c. For longer runs (over 90 ft.), it is best to use more cable than to attempt to “load up” on one main cable, see “Voltage Drop” formula table in Section III, Cable Installation Guidelines.

# DANGER

## **Risk of Electrical Shock or Electrocution.**



This lighting system must be installed by a licensed or certified electrician or a qualified pool serviceman in accordance with the National Electrical Code and all applicable local codes and ordinances. Improper installation will create an electrical hazard which could result in death or serious injury to pool users, installer, or others due to electrical shock, and may also cause damage to property. Read and follow the specific instructions below.  
Always disconnect power to the pool light at the circuit breaker before servicing the light. Failure to do so could result in death or serious injury to serviceman, users, or others due to electrical shock.

### D. Installing the Fixtures.

1. Insert the ground spike vertically into the soil.
  - a. Do not force. For best results, soak the ground with water before inserting the spike. A sharp object may also be used to pierce the ground.
  - b. To reinforce the light, take a section of fence post or pipe and wedge it against the spike while driving it into the ground. Cement may also be used but the wires must be protected in a sleeve.
  - c. Once the fixture is in place, take the lead wire from the lamp and split it into a “V” shape about 12 in. apart. Pull approx. 1/2 in. to 3/4 in. of insulation off of each end exposing the copper wires. Do not cut the copper wires.
2. Bring the main cable close to the fixture lead wires. Leave a little slack for flexibility.
  - a. Cut the main cable completely in half next to where the fixture is mounted.
  - b. Split each end of the cut wire into a “V” shape about 12 in. apart and pull approx. 1/2 in. to 3/4 in. of insulation off, exposing the copper wires. Do not cut the copper wires.
  - c. Reconnect the main cable by twisting the two sections back to their original configuration, like-to-like sides to insure polarity. This procedure allows you to “tap” into the main cable line.
3. Once the cable is reconnected, take one of the fixture lead wires and attach it to one of the main cable connections by twisting the wires together.
  - a. Duplicate this procedure on the other set of wires. You now have introduced the fixture to the main cable system.
  - b. Place a wire nut connector on each connection. There should be two connections of three wires.
  - c. For best results, apply a silicon-based gel around the wire nut connectors and wrap each connection with a good electrical tape. This will help keep moisture off of the connection and help prevent a break down due to electrolysis.

- d. An alternate method would be to solder each connection instead of using wire nuts. Always insulate the connection with electrical tape.

## NOTE

We recommend that you test the system before waterproofing and/or burying the main cable. A weak connection will adversely affect the operation of the system. Note: Silicon-based gel connectors are available at most irrigation supply retailers. These work especially well in excessively wet conditions.

4. For additional information and tips refer to Section VII, Trouble Shooting.

## SECTION VI. COMMON INSTALLATIONS/LAYOUTS

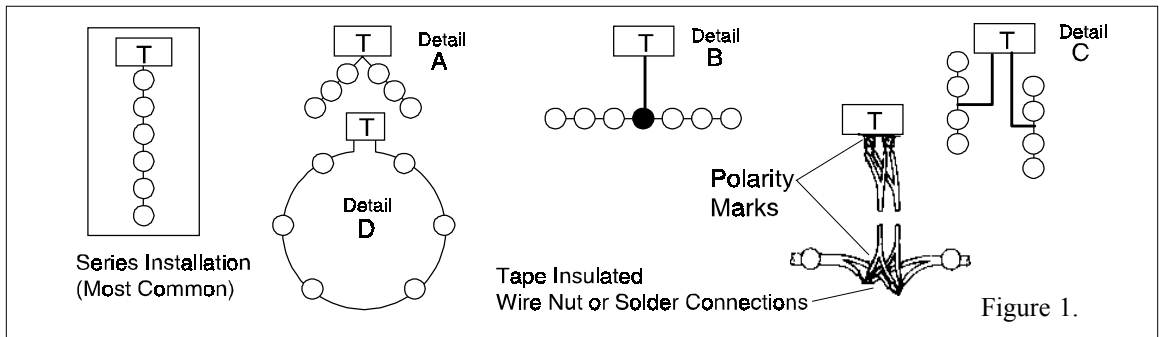

## SECTION VII. TROUBLESHOOTING

- A. If the Entire System Will Not Light:
  1. Check the 110V outlet for power. Use a voltmeter to verify power.
  2. Check the transformer for power.
  3. Check the switch or photocell for power.
  4. Visually inspect the cable for possible cuts.
- B. If Only Parts of the System Work:
  1. Check the bulbs for operation. Are the filaments intact? Do the lamps light?
  2. Visually inspect all connections for possible cuts or weak connections.
  3. Check the cable after the last working light.
- C. If Lights Burn Dim:
  1. Reduce the number of lights or total wattage.
  2. Run a loop back to the transformer for extra power, see Figure 1, Detail D.
  3. Run an additional cable from the transformer to the dim light(s).
  4. Reconnect the system with heavier cable.

---

## Glossary of Terms

Voltage	A measure of the force pulling electricity through a circuit.
Amperage	A measure of the amount of electricity flowing in a circuit.
Lumens	Measure of the brightness of the light output.
Wattage	Measure of electricity consumed.
Transformer	An electrical device that “transforms” or reduces the electrical pressure from the house voltage (usually 110V to 12V).
Resistance	Electrical restrictions on the cable impairing the flow of current.
Voltage Drop	Percentage of diminished voltage. Bulbs will burn brightest at peak voltage (0 drop).
Home Run	A cable run originating from the transformer.
Looping	Continuing the cable run back to the transformer after the last light. This may alleviate some of the voltage drop by “feeding” the run from both ends.

---

## SECTION VIII. TECHNICAL DATA

### A. Replacement Parts

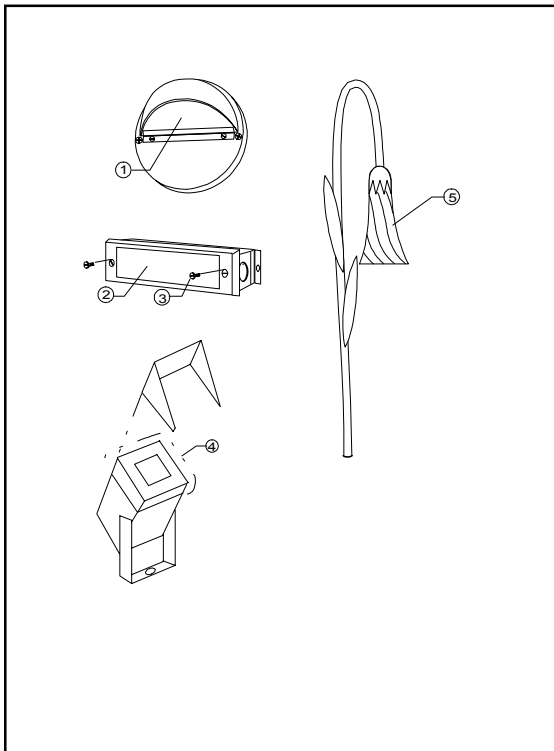

Item No.	Part No.	Description
1	24529200	Glass w/bracket for Half Moon wall fixture
2	24529300	Glass for Brick/Glass wall fixture, w/screws
3	24529100	Screw, 8-32 X 5/8 in. Verde finish
4	24529400	Cover w/glass for Directional Spot fixture
5	24529000	Shade, glass, Frosted Flower fixture

**SAVE THESE INSTRUCTIONS.**

**This page is blank.**

Pentair Pool Products

1620 Hawkins Rd., Sanford, NC 27330 • (919) 774-4151

10951 W. Los Angeles Ave., Moorpark, CA 93021 • (805) 523-2400

