

Model EZ3400 Owner's Manual

4-Function Hand-Held Wireless Remote Control

IMPORTANT SAFETY INSTRUCTIONS
READ AND FOLLOW ALL INSTRUCTIONS
SAVE THESE INSTRUCTIONS

Table of Contents

SECTION I.	APPLICATION	2
SECTION II.	KIT CONTENTS	2
SECTION III.	RECEIVER	2
SECTION IV.	POWER CENTER	2
SECTION V.	CABLE SPLITTERS (Optional)	3
SECTION VI.	HAND-HELD REMOTE	3
SECTION VII.	RECEIVER CIRCUIT BOARD	3
SECTION VIII.	RECONFIGURING FUNCTIONS ON THE HAND-HELD REMOTE	4
SECTION IX.	CUSTOMIZING THE COMMUNICATION LINK	5
SECTION X.	HAND-HELD REMOTE BATTERY REPLACEMENT	5
	TROUBLE-SHOOTING	6
	WARRANTY	7

WARNING



Risk of electrical shock or electrocution. If your Compool electrical panel includes circuit breakers (almond colored steel enclosure), it is also required that the main power into the home be switched off at the main circuit breaker box.

WARNING

Before installing this product, read and follow all warning notices and instructions which are included. Failure to follow safety warnings and instructions can result in severe injury, death, or property damage. Call (800) 831-7133 for additional free copies of these instructions.

Important Notice



Attention Installer.

This manual contains important information about the installation, operation and safe use of this product. This information should be given to the owner/operator of this equipment.

Pentair Pool Products

1620 Hawkins Ave., Sanford, NC 27330 • (919) 774-4151
 10951 West Los Angeles Ave., Moorpark, CA 93021 • (805) 523-2400



Because **reliability** matters most

SECTION I. APPLICATION

Used in conjunction with the following Compool Control Systems:

CP3400, CP3600, CP3800, CP3810 and CP3830.

Provides switching of four remote control circuits from a wireless hand-held remote.

It is typically used for activating the spa circulation, and for operating three auxiliary pieces of equipment (such as lights, jet pump, air blower, waterfall, etc.).

Each of the four functions on the hand-held remote has an "ON" and an "OFF" button.

SECTION II. KIT INCLUDES:

- 1-qty. Hand-held Remote (P/N 520018)
- 1-qty. Receiver (with 8 ft. flexible conduit and (1) 9½ ft. cable inside)
- 4-qty. Plastic Anchors (for mounting Receiver to concrete or stucco walls)
- 4-qty. Mounting screws (for mounting Receiver to a flat surface)

SECTION III. RECEIVER

The functional range of the wireless remote (from Hand-held Remote to Receiver) is approximately 150 ft. line-of-sight. The Receiver should be mounted at a convenient location (on a flat surface) a minimum of 5 ft. above ground level to optimize the functional range of the Hand-held Remote.

CAUTION

The Receiver should be mounted a minimum of 8 to 10 feet away from any air blower, which may be part of the equipment set. The Receiver will not operate properly if it is close to a blower which is operating.

In order to mount the Receiver, it will be necessary to remove the two retaining screws located on the underside of the Receiver, and carefully slide the Receiver case up and off of its backplate. Temporarily position the backplate against its mounting surface so that the Receiver is oriented in an upright position (with antenna pointing upwards, and flexible conduit protruding from the bottom of the Receiver). The circuit board may need to be temporarily removed. Carefully disconnect the modular connector at the bottom of the circuit board and slide the board out of the backplate. Use a pencil to mark the four mounting points, and drill 3/32 in. dia. holes. For stucco or block walls, drill 3/16 in. dia. holes and insert the four plastic anchors (provided). Reposition the backplate over the mounting points and secure with the four mounting screws (provided). Carefully slide the circuit board back into the backplate and connect the modular connector. Then slide the Receiver case back onto the backplate, and secure using the two retaining screws.

SECTION IV. POWER CENTER

Disconnect power by switching off all circuit breakers pertaining to pool and spa.

WARNING

If your Compool electrical panel includes circuit breakers (almond colored steel enclosure), it is also required that the main power into the home be switched off at the main circuit breaker box.

Loosen the LOCK SCREW on handle of hinged faceplate in the left-side of Power Center, and swing open to expose the low-voltage wiring compartment. If the Power Center incorporates a circuit breaker subpanel, it will be necessary to temporarily remove the breaker panel in order to access the low-voltage wiring compartment.

Insert the flexible conduit (attached to Receiver) into the low-voltage compartment by threading through the plastic bushing on the underside of the Power Center enclosure.

Locate the silver cable (with modular connector attached) protruding from the flexible conduit, and plug it into the Power Center circuit board at COM PORT socket.

SECTION V. CABLE SPLITTERS (OPTIONAL)

Most Power Center circuit boards include 2-qty. COM PORT sockets. However, if there is no unused COM PORT socket available, it will be necessary to use a Cable Splitter (P/N 6CONDUAL).

Disconnect the existing Indoor Remote cable from the COM PORT socket.

Plug the short cable (attached to one end of Cable Splitter) into COM PORT socket.

Plug existing Indoor Remote cable into one of the open sockets of the Cable Splitter.

Plug the silver cable (protruding from flexible conduit of Receiver) into the other open socket of the Cable Splitter.

SECTION VI. HAND-HELD REMOTE

The Hand-held Remote will control four circuits.

Although the Remote is capable of duplicating any four of the Equipment Buttons located on the Indoor Remote, it has been preset at the factory to control the following:

Spa Pushbutton activates the Spa circuit (duplicates Spa Button on Indoor Remote).

“A” Pushbutton activates Auxiliary 1 circuit (duplicates Button 1 on Indoor Remote).

“B” Pushbutton activates Auxiliary 2 circuit (duplicates Button 2 on Indoor Remote).

“C” Pushbutton activates Auxiliary 3 circuit (duplicates Button 3 on Indoor Remote).

If you would like to control circuits other than Spa, Aux1, Aux2 and Aux3, it is possible to make adjustments to the circuit board located inside the Receiver unit.

USING THE HAND-HELD REMOTE

To activate a circuit, press and hold the appropriate "ON" button for at least *a full second*. To deactivate, press and hold the OFF button in the same manner.

IMPORTANT

The Hand-held remote may be used with wet hands, but should never be submersed in water, as this could damage the unit. If accidental submersion occurs, dry unit out by removing battery cover and removing battery. Position unit so that water can drain out. Reassemble when completely dry.

SECTION VII. RECEIVER CIRCUIT BOARD

To access the circuit board inside the Receiver, remove the two retaining screws located on the underside of the Receiver, and slide the Receiver case up and off of its backplate. The diagram below gives an overview of the Receiver.

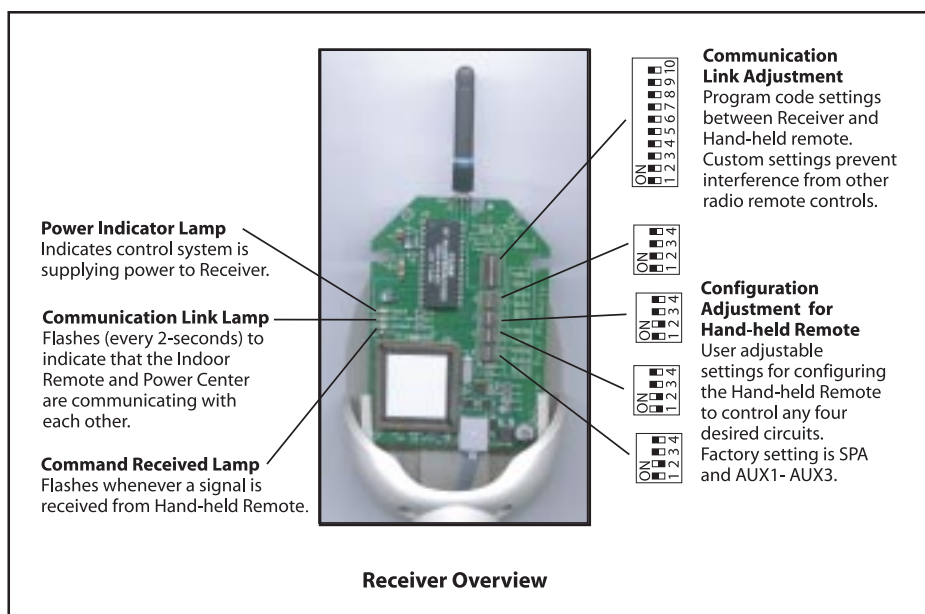

SECTION VIII. RECONFIGURING FUNCTIONS ON THE HAND-HELD REMOTE

There are 4-qty 4-position configuration switches (designated SW1, SW2, SW3 and SW4) located on the Receiver circuit board. These switches are used to configure the four buttons on the Hand-held Remote:

SW1 will configure Spa Button (of the Hand-held Remote).

SW2 will configure "A" Button (of the Hand-held Remote).

SW3 will configure "B" Button (of the Hand-held Remote).

SW4 will configure "C" Button (of the Hand-held Remote).

Each 4-position switch can be reconfigured to activate any circuit on the Control System. Use a paper clip or other blunt instrument to slide the appropriate switch to the "ON" or "OFF" position, in accordance with the diagram below.

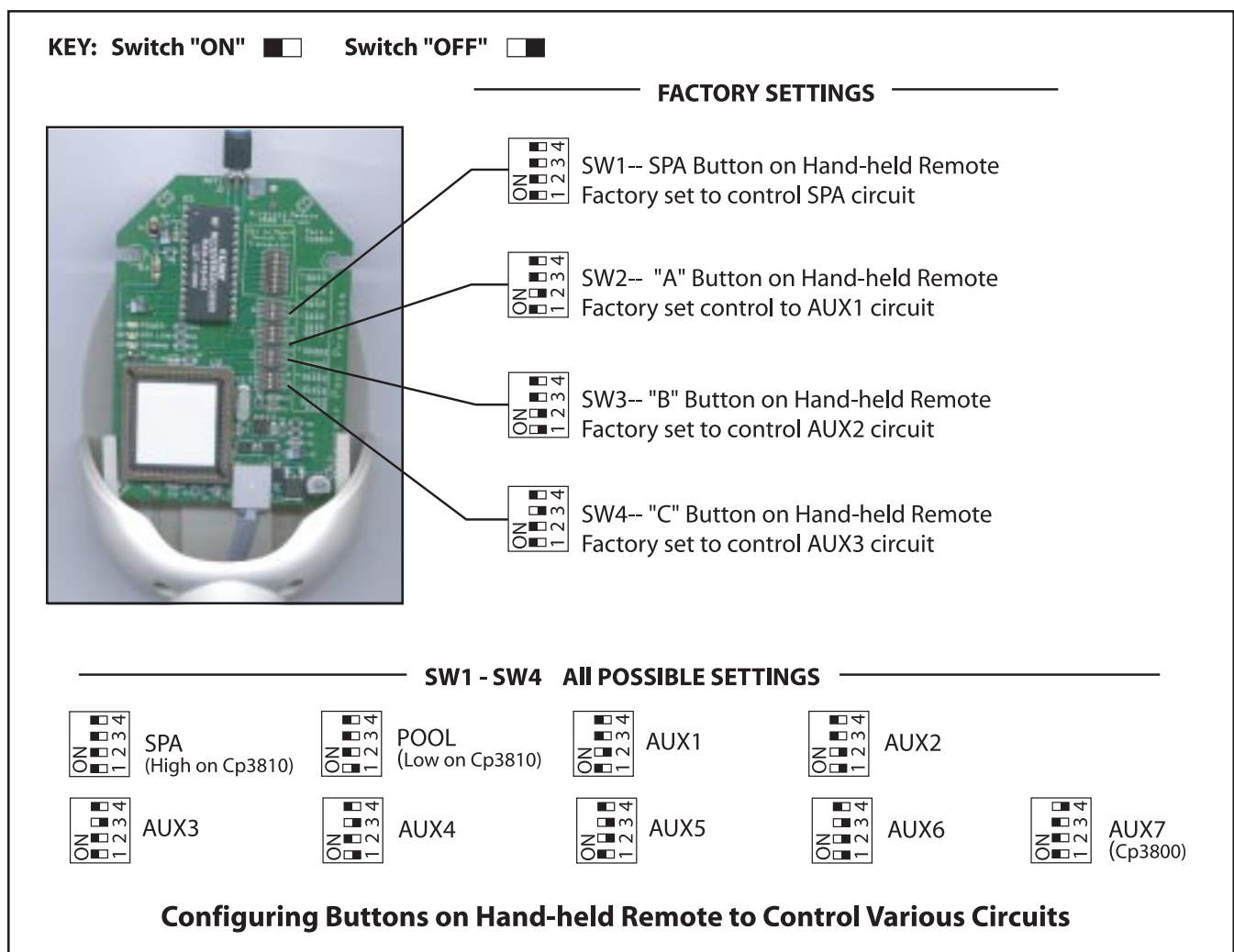

SECTION IX. CUSTOMIZING THE COMMUNICATION LINK

The communication link between the Receiver and Hand-held Remote can be customized to prevent electrical interference. To accomplish this, there is a 10-position configuration switch located on the Receiver circuit board, and inside the Hand-held Remote. Units are shipped from the factory with all switches in the ON position.

If you wish to change this setting, use a paper clip or other blunt instrument and adjust both 10-position configuration switches to matching settings. If the configuration switch setting at the Receiver does not match that of the Hand-held Remote the communication link will not function.

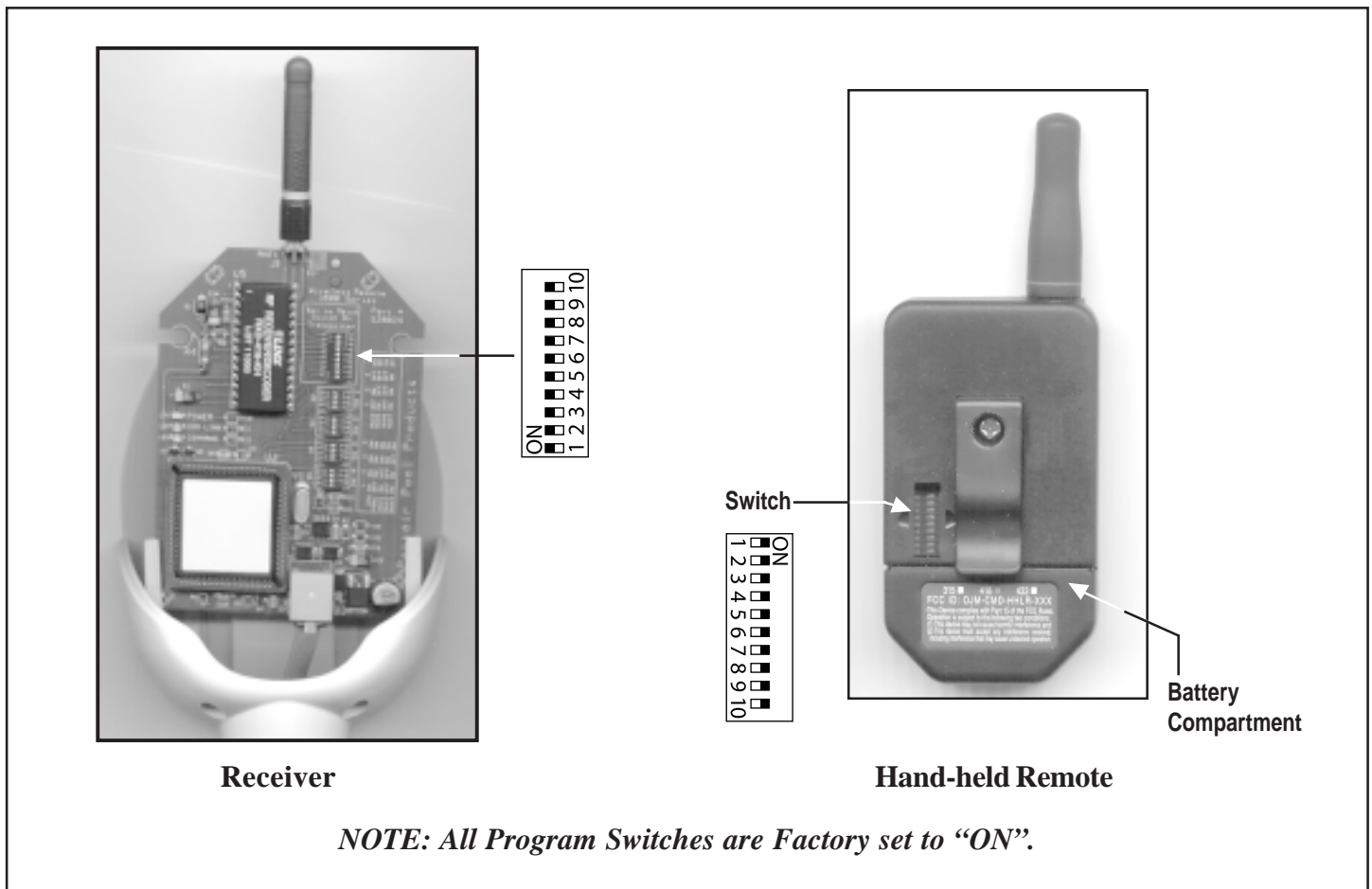

SECTION X. HAND-HELD REMOTE BATTERY REPLACEMENT

With normal use the battery should last for several years. In the event the battery must be replaced, slide the cover from the bottom of the Hand-held Remote. Slide the battery from the retainer clip and discard in accordance with local and/or state ordinances. Replace with 3V lithium battery number CR2032 or equivalent. Slide battery cover onto remote and snap in place.

TROUBLE-SHOOTING

Symptom	Possible Cause	Solution
POWER LED does not light.	LX Control Center does not have power. Defective cable or connection to the LX Control Center. Defective receiver board.	Insure power is being supplied and that the LX Control Center operates correctly without the receiver installed. Verify the function of the board using known good cable set. Contact factory or service center.
COM LINK LED does not light or blink. In normal operation LED will blink at least every 2 seconds.	Defective cable or connection to the LX Control Center. Defective receiver board.	Verify the function of the board using known good cable set. Contact factory or service center.
COMMAND LED does not light when Hand-held Remote button(s) is pressed - unit fails to operate.	Address switches are incorrectly configured. Hand-held Remote battery has failed. Defective Hand-held Remote or receiver.	Verify that the address switches on the Hand-held Remote and receiver board are correct and match. Replace Hand-held Remote battery. Contact factory or service center.
Unit functions, but some circuits do not work, or operate the incorrect circuit.	Circuit selection switches are incorrectly set.	Verify settings of SW1 through SW4 on the receiver board.
Unit fails to operate, or fails to operate dependably at range.	Undue electrical noise. Too many obstructions between the Hand-held Remote and receiver. Receiver unit is too near the ground.	Relocate the receiver away from equipment such as blower motors. Relocate the receiver in a location that provides fewer obstructions to the area the user commonly operates the Hand-held Remote. Relocate the receiver to maximize the distance between the receiver antenna and the ground.
Unit seems to turn on or off circuits without the user / Hand-held Remote.	A nearby home is operating a similar wireless unit.	Select an alternate address code for the Hand-held Remote and receiver. <i>i.e.</i> change the switches on both boards to an alternate, but matching setting.
Unit dependably turns equipment ON, but once equipment is running it does not dependably turn equipment OFF, or range is greatly reduced when equipment is running.	Undue electrical noise is being produced by one or more pieces of equipment in close proximity to the receiver.	Relocate the receiver away from equipment such as blower motors. Relocate the receiver in a location that provides fewer obstructions to the area the user commonly operates the Hand-held Remote.
Unit operates, but has greatly reduced range compared to prior function.	Hand-held Remote battery is failing.	Replace Hand-held Remote battery.

Warranty

Pentair Pool Products warrants to the original purchaser of this electronic control system, for the period of one year from the date of original purchase for use, that any defective product proved to be caused by faulty workmanship or faulty material, will be repaired or replaced at Pentair Pool Products' option at no charge, providing the product is returned to Pentair Pool Products with all transportation charges prepaid.

This warranty covers the Receiver Enclosure, Circuit Board, Hand-held Remote, conduit and cabling including all components and parts. It extends to the consumer who made the original retail purchase only and is not enforceable by any other party.

This limited warranty applies only to controls which have been installed and maintained in strict accordance with installation and operating instructions provided by Pentair Pool Products, using installation hardware supplied and/or recommended in writing by Pentair Pool Products, and to controls which have been connected to the correct supply voltage.

This limited warranty does not apply to any controls which have been repaired or altered by anyone other than Pentair Pool Products or a person authorized by it; or which have been subject to misuse, neglect or accident; or which have been damaged by wind, rain, lightning, freezing or other cause, thing, person, or act of God; or which have been subject to damage in transit, during installation, or by someone other than Pentair Pool Products; or which have been damaged because of a defect in a component or part which is not part of the Compool Control System; or upon which the serial number or manufacture date has been altered, effaced or removed.

This warranty gives you specific legal rights and you may also have other rights which vary from State to State. Pentair Pool Products does not authorize any person to create any other obligation or liability in connection with Compool controls.

Pentair Pool Products makes no warranty of merchantability or fitness for any use. Any implied warranty applicable to Pentair Pool Products controls is limited in duration to the duration of this written warranty. Unless state law provides otherwise, Pentair Pool Products shall not be liable for consequential or incidental damages resulting from breach of this written warranty or any implied warranty, or any inconvenience, loss of time, or incidental expenses such as telephone calls.

Pentair Pool Products shall not be liable for any labor charges associated with the removal or reinstallation of any so-claimed defective products.

To exercise this warranty, send defective parts, with copy of dated receipt and a brief description of the problems encountered, postage prepaid, to:

Pentair Pool Products
10951 West Los Angeles Avenue
Moorpark, CA 93021

For questions, repairs, replacement parts, or information on possible Authorized Service Centers within your vicinity call:

Pentair Pool Products ~ 800-831-7133

Or visit us on the Internet at www.pentairpool.com

Pentair Pool Products

1620 Hawkins Ave., Sanford, NC 27330 • (919) 774-4151

10951 West Los Angeles Ave., Moorpark, CA 93021 • (805) 523-2400

