

# STA-RITE®

## VERTICAL GRID DE FILTERS

### O W N E R ' S M A N U A L

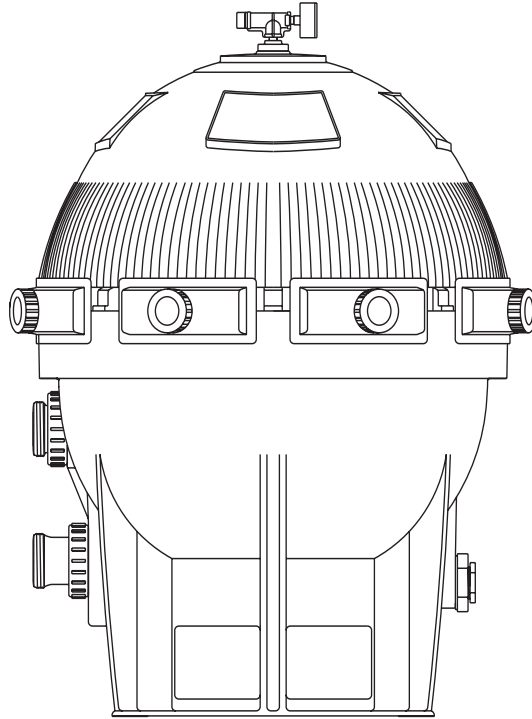

---

### INSTALLATION, OPERATION & PARTS

### MODELS

S7D75

S8D110

This manual should be furnished to the end user of this filter; its use will reduce service calls and chance of injury and will lengthen filter life.



---

#### **Pentair Water Pool and Spa, Inc.**

© 2010 Pentair Water Pool and Spa, Inc. All rights reserved. This document is subject to change without notice.

1620 Hawkins Ave., Sanford, NC 27330 • (919) 566-8000

10951 West Los Angeles Ave., Moorpark, CA 93021 • (805) 553-5000 -

**Customer Support: Call (800) 831-7133**

Sta-Rite® and Pentair Water Pool and Spa® are registered trademarks of Pentair Water Pool and Spa, Inc. and/or its affiliated companies in the United States and/or other countries. Unless noted, names and brands of others that may be used in this document are not used to indicate an affiliation or endorsement between the proprietors of these names and brands and Pentair Water Pool and Spa, Inc. Those names and brands may be the trademarks or registered trademarks of those parties or others.

Printed in U.S.A.

03-17-10

**S284** (Rev. B)

# VERTICAL GRID DE FILTERS

To avoid unneeded service calls, prevent possible injuries, and get the most out of your filter, READ THIS MANUAL CAREFULLY!

The Sta-Rite System 3 Vertical Grid DE Filter:

- Is designed to filter water for swimming pools.
- Is an excellent performer; durable, reliable.

## Table of Contents

Safety Instructions.....	3
General Information.....	4
Installation .....	5
Specifications .....	6
Initial Startup.....	7
Filter Disassembly / Assembly.....	8
Cleaning the Filter .....	9
Filter Backwash Procedure.....	9
Manual Filter Cleaning Procedure .....	10
Chemical Cleaning Procedure .....	11
System Inspection/Winterizing.....	12
Troubleshooting Guide .....	13
Repair Parts List.....	14-15



## READ AND FOLLOW SAFETY INSTRUCTIONS!

 This is the safety alert symbol. When you see this symbol on your filter or in this manual, look for one of the following signal words and be alert to the potential for personal injury.



 **DANGER** warns about hazards that will cause death, serious personal injury, or major property damage if ignored.

 **WARNING** warns about hazards that can cause death, serious personal injury, or major property damage if ignored.

 **CAUTION** warns about hazards that will or can cause minor personal injury or property damage if ignored.

NOTICE indicates special instructions not related to hazards.

Carefully read and follow all safety instructions in this manual and on equipment. Keep safety labels in good condition; replace if missing or damaged.





 **WARNING** Incorrectly installed or tested equipment may fail, causing severe injury or property damage. Read and follow instructions in owner's manual when installing and operating equipment.  
 **Hazardous pressure** Have a trained pool professional perform all pressure tests.

1. Do not connect system to a high pressure or city water system.
2. Use equipment only in a pool or spa installation.
3. Trapped air in system can cause explosion. BE SURE all air is out of system before operating or testing equipment.

Before pressure testing, make the following safety checks:

- Check all clamps, bolts, lids, and system accessories before testing.
- Release all air in system before testing.
- Tighten Sta-Rite pump trap lids to 30 ft. lbs. (4.1 kg-cm) torque for testing.
- Water pressure for test must be less than 25 PSI (172 kPa).
- Water Temperature for test must be less than 100° F. (38° C).
- Limit test to 24 hours. After test, visually check system to be sure it is ready for operation. Remove pump trap lid and retighten hand tight only.

NOTICE: These parameters apply to Sta-Rite equipment only. For non-Sta-Rite equipment, consult equipment manufacturer.

	 <b>WARNING</b>	<b>BEFORE WORKING ON FILTER:</b>
	<p><b>If filter clamps are adjusted or removed under pressure, tank may explode, causing severe injury or major property damage.</b></p>	<ol style="list-style-type: none"> <li>1. Stop pump.</li> <li>2. Open air release valve.</li> <li>3. Release all pressure from system.</li> </ol>
	 <b>WARNING</b>	<b>BEFORE WORKING ON PUMP OR MOTOR</b>
	<p><b>Filter pumps require hazardous voltage which can shock, burn, or cause death.</b></p>	<p>Disconnect power to motor at main circuit breaker. Discharge motor capacitor to ground.</p>

## GENERAL INFORMATION

- Clean a new pool as well as possible before filling pool and operating filter. Excess dirt and large particles of foreign matter in the system can cause serious damage to the filter and pump.
- With a diatomaceous earth (DE) filter system in place and operating correctly, clean water is returned to the pool faster than pool water is being contaminated. A typical pool installation will require approximately one week to obtain and maintain the sparkle that your filter is capable of giving you.
- DO NOT use more than the recommended amount of DE in your filter. To do so can cause a buildup of DE and "bridging" between the elements which will plug the filter.

 If filter is improperly disassembled or assembled, it can explode under pressure! To avoid danger of severe injury or major property damage, always follow service instructions in this manual when working on filter!

 NEVER operate this filter system at more than 50 pounds per square inch (50 PSI/345kPa) pressure! Be sure filter pressure gauge operates when system is operating. If pressure gauge is damaged or does not work, replace it.

 Purge all air from system before operating system. NEVER operate filter with air trapped inside.

- On a new pool installation, we recommend:

1. Disassemble the filter after the initial cleanup.

 To prevent severe injury or major property damage, exactly follow "Filter Disassembly/Assembly Procedure" on Page 8.

2. Remove and hose down the element assembly to remove contaminants.

- It is a good idea to remove the element assembly once a year and soak it in a filter cleaning solution to remove accumulated body oils, etc.; see Page 11, "Chemical Cleaning Procedure".
- Cleaning interval is based on pressure differential, not on length of time filter is operated. Different water conditions will have different normal cleaning intervals. If backwashing filter is not possible, use "Manual Filter Cleaning Procedure", Page 10, at regular intervals to clean filter.
- Check local codes for restrictions on backwash to waste piping, separation tank requirements and spent D.E. disposal requirements.

### WARNING

**Hazardous pressure.  
Can cause severe  
injury or major  
property damage  
from tank blow up.**

Release all pressure  
and read instructions  
before working on filter.

# INSTALLATION

Installation of filter should only be done by qualified, licensed personnel.

## Filter mount must:

- Provide weather and freezing protection.
- Provide space and lighting for easy access for routine maintenance. (See Figure 1 and Table II, Page 6, for space requirements.)
- Be on a reasonably level surface and provide adequate drainage.
- Be as close to pool as possible to reduce line loss from pipe friction.

## Piping:

- Piping must conform to local/state plumbing and sanitary codes.
- Use Teflon tape or Plasto-Joint Stik<sup>®</sup> on all male connections of plastic pipe and fittings. DO NOT use pipe compounds on plastic pipe; it will cause the pipe to crack. Do not use sealant on unions—assemble them dry and hand tight.
- Support pipe independently to prevent strains on filter or valve.
- Use 2" (51mm) pipe to reduce pressure losses as much as possible.  
NOTICE: Filter may be located away from pool, but for adequate flow larger pipe may be needed. Check local codes for remote installation.
- Fittings restrict flow; for best efficiency use fewest possible fittings.
- Keep piping tight and free of leaks: pump suction line leaks may cause trapped air in filter tank or loss of prime at pump; pump discharge line leaks may show up as dampness or jets of water.
- NOTICE: Overtightening can crack filter ports.

TABLE I - Sta-Rite valves for use with DE filters

Port Size	Part Number
2"	Multi-port 18201-0200*
2"	Plastic Slide WC212-134P*

\* Recommended for best energy conservation.

**NOTICE:** Use of valves other than those listed above could cause reversed water flow through filters and damage to internal filter components.

## Valves:

- A check valve installed ahead of filter inlet will prevent contaminants from draining back into pool.
- A check valve installed between filter and heater will prevent hot water from backing up into filter and deforming internal components.
- Install Sta-Rite Two Position Slide Valve or Multiport Selector Valve with filter. See Table I.
- Filter ports and valve ports are furnished with union connections. DO NOT use pipe sealants on union collar (nut).
- Use care before assembly not to damage union sealing surfaces or O Ring.
- To allow recirculation during precoat (if precoat pot is used), install a recirculation line with shut-off between pad return line and pump suction.

## Electrical

- All wiring, grounding and bonding of associated equipment must meet local and/or National Electrical Code standards.

Plasto-Joint Stik<sup>®</sup> is a registered trademark of La-Co Industries, Inc.

# SPECIFICATIONS

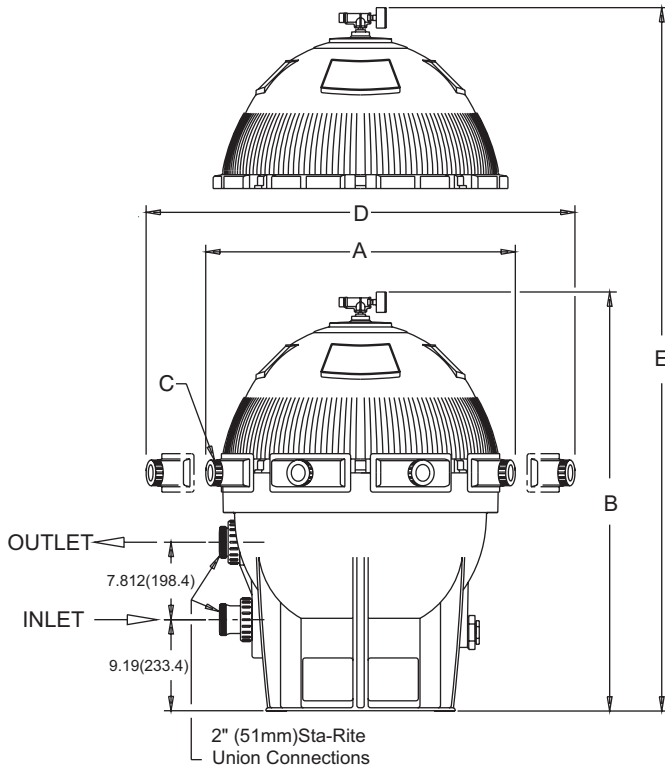

FIGURE 1 – Dimensions in inches (mm)

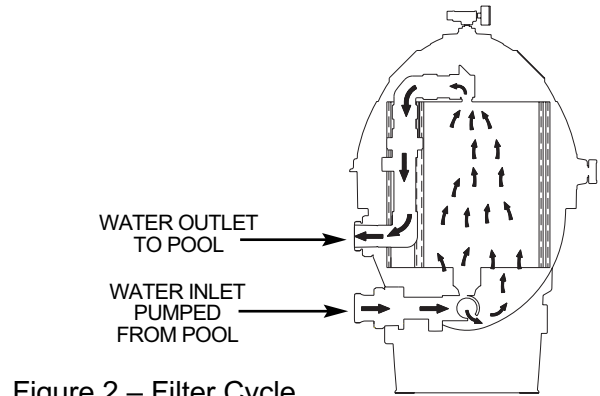

Figure 2 – Filter Cycle

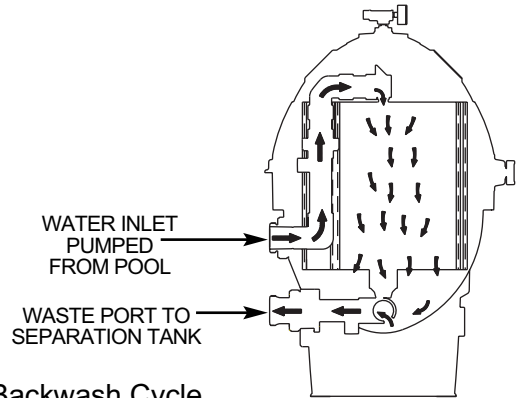
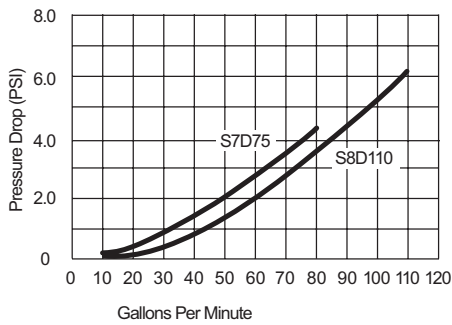

Figure 3 – Backwash Cycle



Pressure Drop Curve

TABLE II - SPACE REQUIREMENTS IN INCHES (MM)

Model No.	A	B	C*	D	E
S7D75	28½(724)	42(1067)	7	36(914)	53½(1359)
S8D110	32½(826)	42¼(1074)	8	40(1020)	54¼(1378)

\* Number of clamps.

TABLE III - APPROVED DE

Use only the following DE or equal:

World Minerals, Inc.	Celite® 545
Eagle-Picher	Celatom®

TABLE IV - FILTER SPECIFICATIONS & OPERATING INFORMATION

Filter Model:	S7D75	S8D110
Filter Area in Sq. Ft. (M <sup>2</sup> )	37 Sq. Ft. (3.44)	53 Sq. Ft. (4.92)
Lbs. (Kg) of D.E. Used	3.7 (1.7)	5.3 (2.4)
Max. Flow Rate in GPM (LPM)	74 (280)	106 (401)
NSF Public Pool Flow Rate in GPM (LPM)	72 (280)	106 (401)
Max. Operating Pressure in PSI (kPa)	50 (345)	50 (345)

NOTICE: 1/2 pound of DE will fill a one-pound coffee can.

Celite® is a registered trademark of Celite Corporation, and Celatom® is a registered trademark of EP Minerals, LLC LTD.

## **⚠ WARNING**



**Hazardous pressure.  
Can cause severe  
injury or major  
property damage  
from tank blow up.**

Release all pressure  
and read instructions  
before working on filter.

## **INITIAL START-UP**

**⚠** Be sure pump is OFF before starting procedure.

**⚠** Do not operate these filters at more than 50 PSI (345 kPa) under any circumstances!

**⚠ CAUTION** To prevent serious damage to the element fabric, NEVER run you DE filter without a diatomaceous earth precoat!

**⚠ CAUTION** To avoid damage to internal filter components, never change handle position on control valve while pump is running.

1. Make sure all clamps are in place and knobs are securely hand-tight.
2. Set valve to 'filter' position.
3. Fill trap on pump with water.
4. Open air release valve on top of filter assembly (Key No. 3, Page 14).
5. Start pump to purge air from system.
6. When steady stream of water comes from air release valve, close the valve.
7. To prepare precoat slurry, mix diatomaceous earth (DE) and water. See Table IV or instruction decal on filter shell for amount of DE to use.
8. Empty slurry slowly into skimmer to precoat filter element with an even filtering cake.

**⚠** Close valve before air is drawn into system.

NOTICE: To avoid bridging between filter grids, do not use more DE than 0.1 pound per square foot of filter area (0.49 kilos per square meter).

After filter is operating, record filter pressure gauge reading in owner's manual for future use.

NOTICE: When installed on a newly plastered pool, after approximately 48 hours of operation disassemble filter and clean out plaster dust (see "Manual Filter Cleaning Procedure", Page 10).

**⚠** To avoid severe injury or major property damage, exactly follow instructions under "System Disassembly/Assembly" (Page 8)!

Remove and thoroughly clean filter element assembly. Use cleanser or detergent and a bottle brush to remove plaster dust (see Figures 8 and 9, Page 10).

When installed on a pool with vinyl liner or painted bottom, thoroughly backwash and clean filter element after 48 hours of operation to remove construction debris (see "Filter Backwash Procedure", Page 9).

## FILTER DISASSEMBLY/ ASSEMBLY PROCEDURE

**CAUTION** To avoid equipment damage and personal injury, never change handle position on control valve while pump is running.

### BEFORE DISASSEMBLING FILTER:

- !** 1. STOP PUMP.
- 2. OPEN air release valve and drain fitting.
- 3. WAIT until all pressure is released and water drained from filter tank and system before loosening clamp knobs.

### Disassembly:

1. Backwash filter according to instructions under “Filter Backwash Procedure”, Page 9.
2. Stop pump.
3. Open air release valve (Key No. 3, Page 14) on top of filter tank to release all air pressure from inside of tank and system.
4. Remove filter drain plug and drain all water from tank.
5. To equalize flange stresses, loosen clamp knobs alternately (that is, on opposite sides of tank) around tank. Remove clamps.
6. Being careful not to damage cord ring (Key No. 21, Page 14), lift upper tank shell (Key No. 7, Page 14) off lower tank shell (Key No. 20, Page 14).

### Assembly:

1. Remove O-Ring slowly to avoid stretching or tearing it.
2. Inspect O-Ring (Key No. 21, Page 14) for cuts, nicks, etc. If O-Ring is damaged, deformed, or has lost its resiliency, replace with a new one.
3. Clean O-Ring area of tank shell (both halves) and O-Ring.
4. Carefully install O-Ring and upper tank shell (Key No. 7, Page 14) on tank bottom (Key No. 20, Page 14).

**NOTICE:** Do not lubricate O-Ring. Lubricants attract dirt and grit and may (especially when petroleum based) damage O-Ring and void warranty.

**NOTICE:** Be sure upper tank shell contacts O-Ring surface evenly and seal area is clean and free from dirt.

5. Install clamp bolts and clamps. Do not tighten clamps yet.
6. See Figures 4 and 5 for clamp tightening sequence. Tighten all clamp knobs securely hand tight.

**NOTICE:** To equalize stresses on tank, be sure to tighten clamps in sequence shown. DO NOT work your way around the filter tightening adjacent clamps.

7. Install air relief valve and gauge assembly on tank.

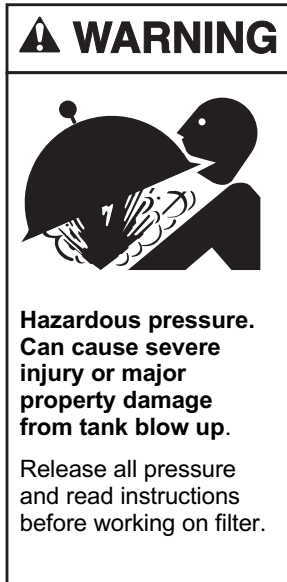

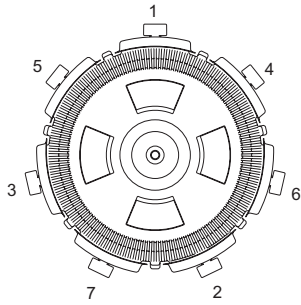

FIGURE 4 - 21" Filter clamp tightening sequence.

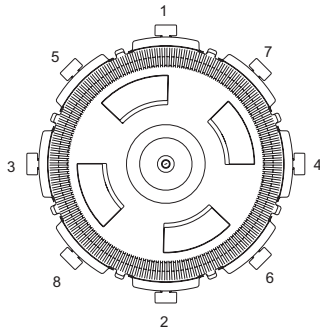

FIGURE 5 - 25" Filter clamp tightening sequence.

## CLEANING THE FILTER

### When to Clean:

NOTICE: If installation does not allow backwashing, use manual cleaning procedure regularly (see Page 10).

1. With a new filter:
  - A. Record filter operating pressure at startup. When pressure reaches 15 PSI (103kPa) above startup operation pressure, stop pump for 15-30 seconds to allow filtering cake to release.
  - B. Restart pump to form new cake. Pressure should now be less than 10 PSI (69kPa) above startup operating pressure.
  - C. If pressure is still more than 10 PSI (69kPa) above startup operating pressure, backwash filter (see below).
2. Thoroughly clean air relief filter screen (Key No. 2, Page 15) on top of manifold EVERY time filter is opened. Be sure to remove all debris from screen. Replace filter screen if damaged.
3. At least twice a year, manually clean filter according to instructions, Page 10. At least once a year, follow instructions under "Chemical Filter Cleaning Procedure", Page 11, as well.

### Filter Backwash Procedure:

**CAUTION** To prevent equipment damage and possible injury turn pump OFF before changing valve position.

NOTICE: Before backwashing with a separation tank, review separation tank owner's manual for instructions.

1. Stop pump.
2. Change valve position.
  - A. If using Multi-port Valve, set to backwash position.
  - B. If using Two Position Slide Valve, raise handle to fully extended position.
3. Start pump, circulating water backwards through filter to flush cake and contaminants into separation tank or waste.
4. If system has a sight glass, backwash until water in glass runs clear.
5. If system does not have a sight glass:
  - A. Backwash one minute.
  - B. Stop pump; reset valve to 'FILTER' position.

**CAUTION** Stop pump before changing valve setting!

- C. Restart pump; filter for 20 seconds.
- D. Repeat steps A, B, C three times. Cycling is effective when cake and contaminants are difficult to break and flush out of filter.

NOTICE: Do not vacuum pool while backwashing filter.

6. Stop pump.
7. Open air release valve and release ALL pressure from tank and system.
8. Follow 'Disassembly' procedure, Page 8, to remove top of filter.

**WARNING** Hazardous pressure. Risk of severe personal injury and major property damage if tank is opened while under pressure or while pump is running.

9. If any DE remains on grids after backwashing, flush filter elements with garden hose to remove it. Be sure to comply with local code for waste DE disposal.
10. Follow instructions under 'Assembly', Page 8, to reassemble filter.
11. Follow 'Initial Start-up' procedure (Page 7, steps 4, 5, 6 and 7) to restart system.
12. Compare pressure reading on gauge with reading recorded after initial startup. The two readings should be very close; if not, do "Manual Filter Cleaning Procedure", below.

**⚠ WARNING**

**Hazardous pressure. Can cause severe injury or major property damage from tank blow up.**

Release all pressure and read instructions before working on filter.

## MANUAL FILTER CLEANING PROCEDURE

### Before Disassembling Filter:

- ⚠ 1. STOP PUMP.
2. OPEN air release valve.
3. WAIT until all pressure is released from filter tank and system before loosening clamps.

**NOTICE:** At least twice a year, disassemble and clean filter regardless of operating pressure readings. This can be done conveniently while winterizing pool in cold climates. Use this method regularly if no means of backwashing is available.

1. Backwash filter as usual, but do not precoat.
2. Disassemble filter (see Page 8).

⚠ To avoid severe injury or major property damage, exactly follow instructions under "Disassembly" (Page 8)!

3. Unscrew union collar holding element assembly in position.

**NOTICE:** Be careful not to lose O-Ring.

4. Grasp element assembly at manifold (Figure 6) and remove it.
5. Hose down element assembly and clean with bottle brush (Figure 7). Use detergent solution or filter cleanser available from a pool service store.

**NOTICE:** To avoid damaging fabric, do not allow filter element to rub on concrete or any abrasive surface during cleaning.

**NOTICE:** Do not expose element cloth to direct sun for long periods. Direct sun will cause the cloth to deteriorate.

6. Inspect grid cloth for tears, calcification, plugged areas, etc. If necessary, soak element in filter cleanser to remove buildup of oils, etc. If calcified, consult pool service company or factory for instructions.
7. Thoroughly clean air relief filter screen (Key No. 2, Page 15) on top of manifold. Be sure to remove all debris from screen.
8. Inspect O-Ring out of the internal union (see Figure 6) for damage. Reinstall it in the groove in the union half if it is undamaged; if it shows tears or cuts replace it.
9. Replace filter element in tank and tighten union firmly hand tight. Union

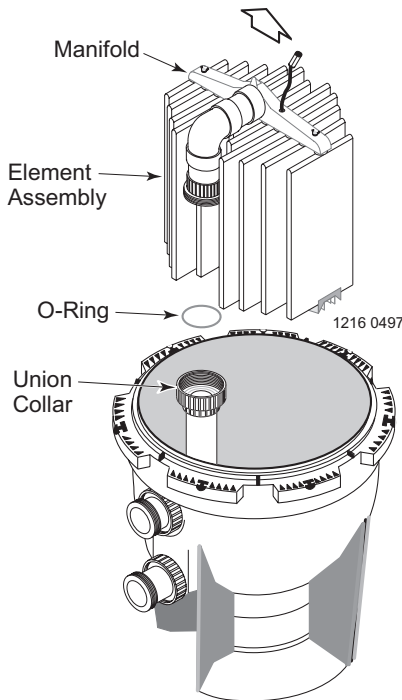

FIGURE 6

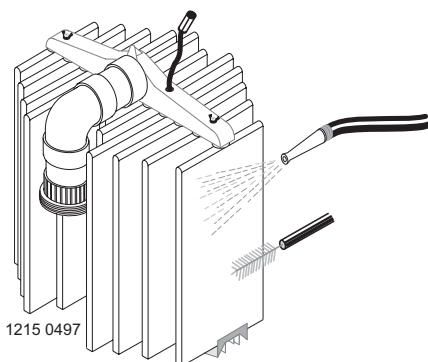



FIGURE 7

collars may need to be cleaned before reassembly.

10. Follow filter assembly procedure, Page 8.

 To avoid severe injury or major property damage, exactly follow instructions under “Assembly” (Page 8)!

11. If unit is returning to service, see “Initial Startup”, Page 7.

12. If cleaning is part of seasonal shutdown, see “Winterizing”, Page 12.

## **WARNING**

**Hazardous pressure.  
Can cause severe  
injury or major  
property damage  
from tank blow up.**

Release all pressure  
and read instructions  
before working on filter.

## **CHEMICAL CLEANING PROCEDURE**

Before Disassembling Filter:

-  1. STOP PUMP.
2. OPEN air release valve.
3. WAIT until all pressure is released from filter tank and system before loosening clamps.

NOTICE: Do not expose element cloth to direct sunlight for long periods. Direct sunlight will cause the cloth to deteriorate.

NOTICE: To avoid damaging fabric, do not allow filter element to rub on concrete or any abrasive surface during cleaning.

NOTICE: Clean filter manually before doing any chemical cleaning.

Filter Disassembly:

 To avoid severe injury or major property damage exactly follow instructions under “Disassembly” (Page 8)!

1. Disassemble and inspect element grid assemblies for tears and worn areas. Replace as needed.
2. Rinse each grid thoroughly with water.
3. Wash each grid with a mild soap solution or commercial filter cleaner. If necessary, soak element grids in filter cleanser to remove buildup of oils, etc.
4. Rinse thoroughly to remove all soap film.
5. If filter elements do not come clean after soaking, have your pool professional acid clean them.

 **WARNING** Risk of burns, explosions, and environmental damage. Only trained professionals should attempt to acid clean filter elements.

7. Reassemble element grids.
8. Inspect inside of filter tank and remove any debris which remains after backwashing.
9. Thoroughly clean air relief filter screen (Key No. 2, Page 15) on top of manifold. Be sure to remove all debris from screen. Replace filter screen if damaged.
10. Follow filter assembly procedure, Page 8.

 To avoid severe injury or major property damage, follow instructions under “Assembly” (Page 8)!

11. If unit is returning to service, see "Initial Startup", Page 7.
12. If cleaning is part of seasonal shutdown, see "Winterizing", Page 12.

## SYSTEM INSPECTION

### General:

Wash outside of filter with a mild detergent and water. Rinse off with hose.

NOTICE: DO NOT use solvents to clean filter; solvents may damage plastic components in system.

NOTICE: Open air bleed valve and bleed all air from filter each time pump is stopped and restarted.

### Weekly Inspection:

1. Skimmer basket- remove debris.
2. Stop pump, release all pressure. Remove trap cover and basket, remove debris.
3. Bleed air from filter each time system is started.
4. For systems with bypass valve, make sure separation tank is not under pressure.
5. Check pump for leaks. If found, see pump owner's manual.
6. Check pump strainer lid for tightness. Do not over-tighten!

## WINTERIZING

1. Clean filter according to instructions, Page 10, before winterizing. Do not winterize with DE precoat on grids or with residual in tank.
2. Open air release valve; open all system valves. Position multiport valve between port positions to allow passage to all ports.
3. Remove drain plugs from trap, pump, valve, filter and separation tank.
4. Drain system piping.
5. Loosen union nuts to drain water from filter internal piping and valve.
6. Cover with plastic or tarpaulin to prevent water entrance and freezing.

# TROUBLESHOOTING GUIDE

## 1. Short Cycle between backwashes:

NOTICE: Time between backwashes will vary with each installation and between different areas of the country. The following causes and remedies are for cycle times shorter than normal for your area.

- A. Chlorine residual too low; maintain proper residual (consult pool professional for recommendation).
- B. Flow rate too high; restrict flow to rated capacity of filter (see instruction plate on filter or specifications on Page 6).
- C. Filter too small; install larger filter or additional filter.
- D. Improper/insufficient precoat; see precoat instructions (Page 7).
- E. Filter elements plugged; thoroughly clean filter (see No. 4, "Plugged Grid Cloth", below, and "Manual Filter Cleaning Procedure", Page 10).
- F. Insufficient cleaning during backwash or annual cleaning; review cleaning instructions, Pages 9-11.
- G. Too much DE; check for bridging between filter elements.
- H. Water is chemically out of balance; consult pool professional.

## 2. Low Flow/High Pressure:

- A. Elements plugged; clean filter thoroughly (see Pages 9-11).
- B. Pipe blocked downstream from filter; remove obstruction.
- C. Piping too small; use larger pipe (consult dealer for sizing).
- D. Filter area too small; install larger filter or auxiliary filter (consult dealer for recommendation)

## 3. Low Flow/Low Pressure:

- A. Pump too small; consult dealer for recommendations.
- B. Plugged pump or plugged hair and lint trap; clean thoroughly.

## 4. Plugged Grid Cloth:

- A. Insufficient precoat; see precoat instructions (Page 7).
- B. Insufficient cleaning; follow cleaning instructions closely and clean thoroughly (see Pages 9-11).
- C. Water is chemically out of balance; consult pool service man.
- D. Excessive air in filter; non-precoated areas may plug. Vent air from tank and check for pump suction pipe leaks. Clean air bleed filter in grid assembly.

## 5. Pool Water Not Clean:

- A. Chlorine dosage too low; maintain adequate chlorine residual (consult pool service man for recommendation).
- B. Broken filter elements passing DE into pool; replace defective grids.
- C. Insufficient or improper precoat; follow precoating instructions and use recommended amount of DE (see Page 7).
- D. Inadequate turnover rate; consult dealer to verify that equipment is properly sized for your pool.

**MODELS**  
**S7D75**  
**S8D110**

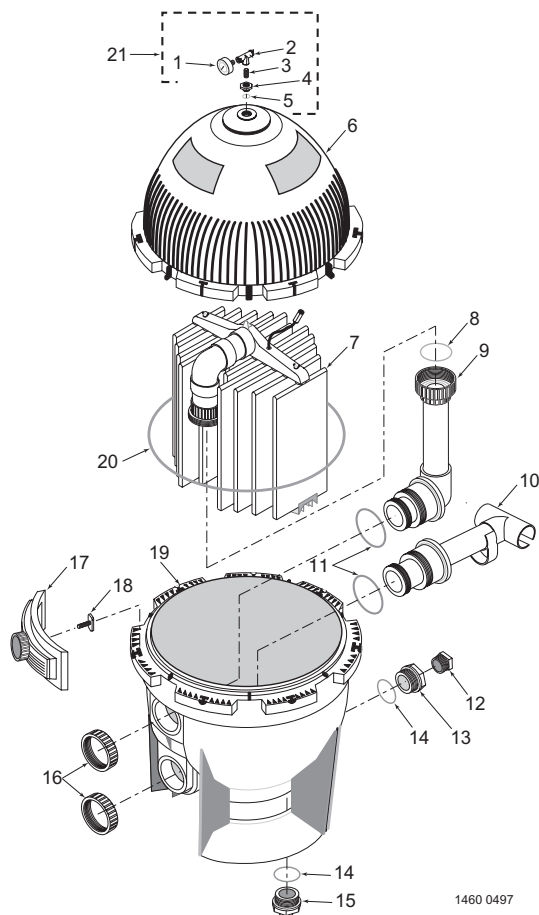

1460 0497

**REPAIR PARTS LIST**

Key No.	Part Description	Model No.	
		S7D75	S8D110
1	2 Inch Gauge	33600-0023T	33600-0023T
2	Air Release Valve	WC212-120P	WC212-120P
3	Close Nipple 1/4 in.	U37-16P	U37-16P
4	Adapter Bushing	24900-0504	24900-0504
5	O-Ring	35505-1423	35505-1423
6	Upper Tank Shell Kit*	24851-9000	24851-9001
7	Filter Element Assembly	23900-1220S	23900-1221S
8	O-Ring	U9-362	U9-362
9	Outlet Assembly	23911-0102	23911-0102
10	Inlet Assembly	23911-0100	23911-0101
11	O-Ring	35505-1425(2)	35505-1425(2)
12	1-1/2" NPT Plug	27001-0022S	27001-0022S
13	Adapter Fitting	24900-0509	24900-0509
14	O-Ring	35505-1424 (2)	35505-1424(2)
15	Drain Plug	24900-0503	24900-0503
16	Bulkhead Retaining Nut	24752-0050(2)	24752-0050(2)
17	Clamp Assembly	24850-0200 (7)	24850-0200 (8)
18	Clamp Bolt	24850-0010(7)	24850-0010(8)
19	Lower Tank Shell	24850-0102S	24851-0103S
20	Cord-Ring	24850-0008	24850-0009
21	Valve and Gauge Assembly (Includes Key Nos. 1-5)	24850-0105	24850-0105
•	Warning Decal	32165-4004	32165-4005
•	Decal - Model Label	32155-4031	32155-4033
•	Decal - Instruction Label	32155-4032	32155-4034

• Not illustrated

Quantity one unless otherwise indicated ( ).

\* Includes all decals and labels.

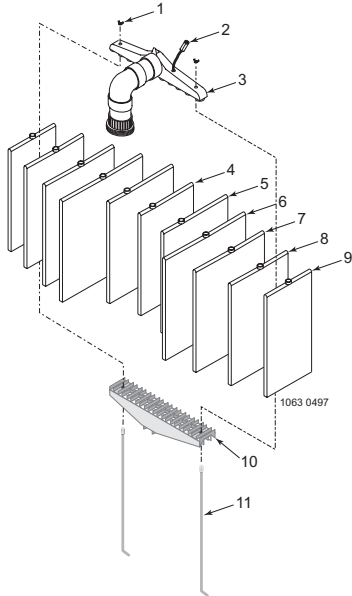

### FILTER ELEMENT ASSEMBLY FOR S7D75

Key No.	Part Description	No. Used	Part No. 23900-1220
1	Wing Nut	2	35402-0074
2	Air Bleed Assembly	1	24800-0120
3	Manifold	1	24800-0100
4	Covered Element 12-7/16"	1	23900-1171
5	Covered Element 13-13/16"	2	23900-1170
6	Covered Element 16-1/2"	2	23900-0033
7	Covered Element 15-3/16"	2	23900-1174
8	Covered Element 12-7/16"	2	23900-1175
9	Covered Element 9-11/16"	2	23900-1173
10	Element Grid Support	1	23900-0350
11	Rod	2	23900-0039

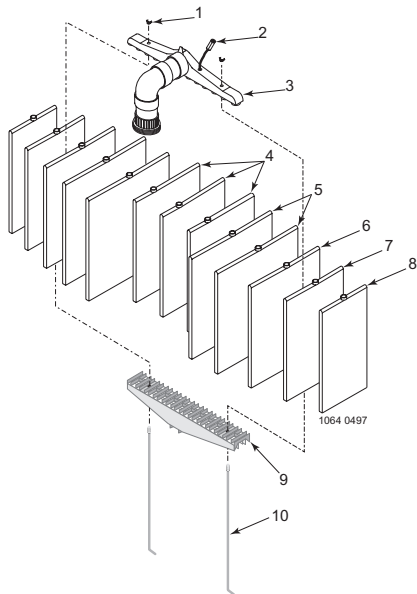

### FILTER ELEMENT ASSEMBLY FOR S8D110

Key No.	Part Description	No. Used	Part No. 23900-1221
1	Wing Nut	2	35402-0074
2	Air Bleed Assembly	1	24800-0120
3	Manifold	1	24801-0101
4	Covered Element 16-1/2"	3	23900-1172
5	Covered Element 19-5/16"	4	23900-0144
6	Covered Element 16-1/2"	2	23900-0033
7	Covered Element 15-3/16"	2	23900-1174
8	Covered Element 11"	2	23900-0032
9	Element Grid Support	1	23901-0350
10	Rod	2	23900-0039

# STA-RITE®

READ, THEN KEEP THESE INSTRUCTIONS FOR FUTURE REFERENCE

